

### 10 MPa double acting hydraulic cylinders with dimensions conforming to ISO standard

- Double acting hydraulic cylinders for 10 MPa with bores from 32 mm to 125 mm.
- Conforming to ISO 10762/JIS B8367-5 standard.
- The adoption of floating cushion realizes smooth startup.
- High-performance cushion provided as a standard feature.
- Seals in sliding parts conform to ISO standards for seal groove.



#### Standard Specifications

Type	Standard type, Switch Set
Nominal pressure	10 MPa
Maximum allowable pressure	Styles other than TC : 10 MPa TC style : 10 MPa ( $\phi 63$ or less), 7 MPa ( $\phi 80$ or more)
Proof test pressure	15 MPa
Minimum operating pressure	Cap side : 0.3 MPa or less Rod side : 0.45 MPa or less
Working speed range	$\phi 32$ to $63$ : 8 to 400mm/s $\phi 80$ to $125$ : 8 to 300mm/s
Working temperature range (ambient temperature)	Standard type : $-10$ to $+80^{\circ}\text{C}$ Switch Set AX type : $-10$ to $+60^{\circ}\text{C}$ WR/WS type : $-10$ to $+70^{\circ}\text{C}$ (No freezing)
Structure of cushioning	Metal fitting system
Adaptable fluid	Petroleum-based fluid (When using another fluid, refer to the table of fluid adaptability.)
Tolerance for thread	JIS 6g/6H
Tolerance of stroke	0 to 250 mm $^{+1.0}_0$ 251 to 1000mm $^{+1.4}_0$ 1001 to 2000mm $^{+1.8}_0$
Mounting style	SD·FA·FB·EA·EB·LA·CA·CB·TA·TC
Accessories	<ul style="list-style-type: none"> <li>● Rod eye (T-end)</li> <li>● Rod clevis (Y-end) with pin</li> <li>● Lock nut</li> <li>● Boots : Nylon tarpaulin : Chloroprene : Conex</li> </ul>

- The maximum allowable pressures for the TC style are applicable when load is applied to only one side with the TC positioned in the center.

#### Terminologies

##### Nominal pressure

Pressure given to a cylinder for convenience of naming. It is not always the same as the working pressure (rated pressure) that guarantees performance under the specified conditions.

##### Maximum allowable pressure

The maximum allowable pressure generated in a cylinder. (surge pressure, etc.)

##### Proof test pressure

Test pressure against which a cylinder can withstand without unreliable performance at the return to nominal pressure.

##### Minimum operating pressure

The minimum pressure that a cylinder placed horizontally without a load can work.

##### Notes

- The cylinder with 32 mm bore conforms to JIS B8367-2.
- Rod diameter and port Rc conform to JIS B8367. (not included in ISO 10762 standards for body)
- Working temperature range depends on the seal material. For details, refer to the selection materials.
- In case that the lock nut is attached to the piston rod end thread, increase the thread length (dimension A).
- Mounting dimensions of the mounting style CA differ from the specifications.
- As for the mounting style EA with 63 mm bore, only the length of centering guide (dimension F) differs from the specification.
- Conex, material of the boots, is the registered trademark of Teijin Limited.

● The following models and mounting dimensions are not specified in JIS B8367-5.

- Double rod types (100H-2D and 100H-2RD)
- Cutting oil proof types (100HW-2 and 100HW-2R)
- Mounting styles SD, FA and FB

### Product Lineup

Unit: mm

Series Variations	Type	Rod dia.	$\phi 32$	$\phi 40$	$\phi 50$	$\phi 63$	$\phi 80$	$\phi 100$	$\phi 125$
General purpose type	Double acting single rod	Standard type 100H-2	●	●	●	●	●	●	●
		Switch Set 100H-2R	●	●	●	●	●	●	●
	Double acting double rod	Standard type 100H-2D	●	●	●	●	●	●	●
		Switch Set 100H-2RD	●	●	●	●	●	●	●
Cutting oil proof type	Double acting single rod	Standard type 100HW-2	●	●	●	●	●	●	●
		Switch Set 100HW-2R	●	●	●	●	●	●	●

- Notes) ● When using a sensor, select a Switch Set Cylinder.  
● No sensor can be mounted onto the standard type cylinder.

#### Double acting single rod

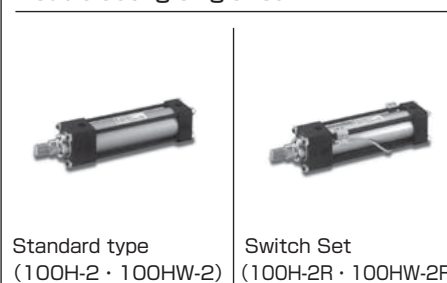

#### Double acting double rod

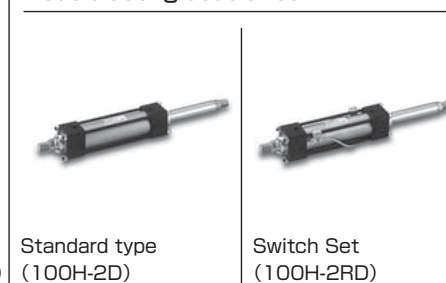

#### Standard Stroke Range Unit: mm

Bore	Stroke
$\phi 32 \cdot \phi 40$	1200
$\phi 50 \cdot \phi 63$	1400
$\phi 80$	1600
$\phi 100$	1800
$\phi 125$	2000

- The above strokes indicate the maximum available strokes for the standard type. Contact us for longer strokes.
- For the rod buckling, check with the buckling chart in the selection materials.

#### Cushion Stroke Length Unit: mm

Bore	Cushion ring length L	Cushion ring parallel part length Le
$\phi 32$	21	6
$\phi 40 \cdot \phi 50$	23	6
$\phi 63$ to $\phi 125$	25	6

- The cushion stroke lengths in case of cylinders used up to the stroke end.
- In the case that a cylinder is not used up to the stroke end, and it is stopped 5 mm or more before the stroke end, the cushioning effect will be weakened.

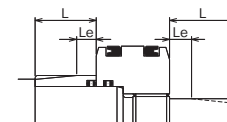

### How to order

#### General Purpose Type

- Standard type 100H-2
- Switch Set 100H-2R

Double acting single rod  
 100H-2 : Standard type  
 100H-2R : Switch Set

Double acting double rod  
 100H-2D : Standard type  
 100H-2RD : Switch Set

- 1 Nitrile rubber
- 2 Urethane rubber
- 6 HNBR
- 8 Combined seal

● For seal structure, refer to the selection materials at the beginning of this catalog.

The item enclosed by broken line needs not to be entered, if unnecessary. ■ Semi-standard specification

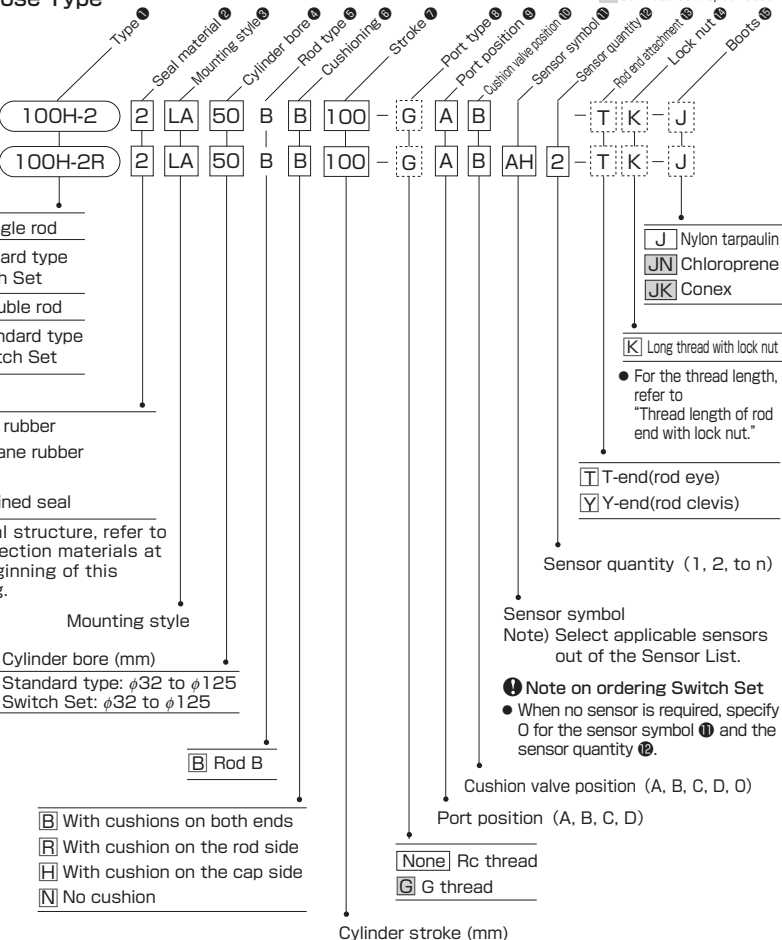

#### Cutting Oil Proof Type

- Standard type 100HW-2
- Switch Set 100HW-2R

Double acting single rod  
 100HW-2 : Standard type  
 100HW-2R : Switch Set

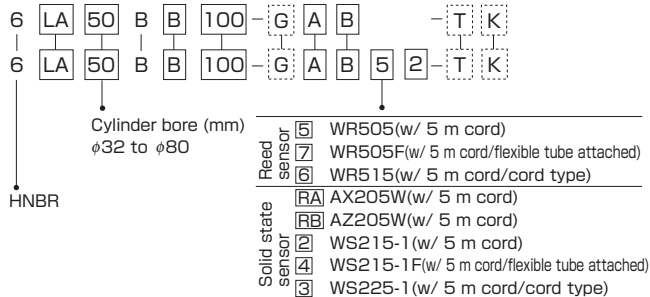

Note) For the details of types other than the above, refer to the specifications of the general purpose type.

### Sensor List

Type	Sensor symbol	Load voltage range	Load current range	Max. switching capacity	Protective circuit	Indicating lamp	Wiring method	Cord length	Applicable load
Reed sensor	AF AX101CE	DC:5 to 30V	DC:5 to 40mA	DC:1.5W AC:2VA	None	LED (Lights in red when sensing)	0.3 mm <sup>2</sup> , 2-core, outer dia. φ 4 mm Rear wiring	1.5m	Small relay, programmable controller
	AG AX105CE								
	AH AX111CE								
	AJ AX115CE	DC:30V or less AC:120V or less	DC:40mA or less AD:20mA or less	None	None	5m			
	AE AX125CE								
	AK AX11ACE						DC:5 to 120V	5 to 20mA	
	AL AX11BCE	DC:5 to 30V	5 to 40mA	1.5W	Provided	LED (Lights in red when sensing)			
	AP AZ101CE						DC:5 to 30V	DC:5 to 40mA	
	AR AZ105CE								
	AS AZ111CE								
	AT AZ115CE	DC:30V or less AC:120V or less	DC:40mA or less AC:20mA or less	None	None	None	5m		
	AN AZ125CE								
	AU AZ11ACE							DC:5 to 120V	
	AW AZ11BCE	DC:5 to 30V	5 to 40mA	1.5W	Provided	LED (Lights in red when not sensing)	0.3 mm <sup>2</sup> , 2-core, outer dia. φ 4 mm, Rear wiring		
AM AX135CE	AC/DC: 90 to 240V							5 to 300mA	B contact output
AY AZ135CE		DC:5 to 50V	DC:3 to 40mA	DC:1.5W AC:2VA	None	LED (Lights in red when sensing)	0.3 mm <sup>2</sup> , 2-core, outer dia. φ 4 mm Rear wiring		
5 WR505	AC:5 to 120V							AC:3 to 20mA	DC:1.5W AC:2VA
7 WR505F		DC:5 to 30V	5 to 40mA	—	Provided	LED (Lights in red when sensing)	0.3 mm <sup>2</sup> , 2-core, outer dia. φ 4 mm, Rear wiring		
6 WR515	DC:5 to 30V							5 to 20mA	—
BE AX201CE-1		DC:5 to 30V	5 to 40mA	—	Provided	LED (Lights in red when sensing)	0.3 mm <sup>2</sup> , 2-core, outer dia. φ 4 mm, Rear wiring		
BF AX205CE-1	DC:5 to 30V							5 to 40mA	—
CE AX211CE-1		DC:5 to 30V	5 to 40mA	—	Provided	LED (Lights in red when sensing)	0.3 mm <sup>2</sup> , 2-core, outer dia. φ 4 mm, Upper wiring		
CF AX215CE-1	DC:5 to 30V							5 to 40mA	—
CH AX21CCE-1		DC:5 to 30V	5 to 40mA	—	Provided	LED (Lights in red when sensing)	0.3 mm <sup>2</sup> , 2-core, outer dia. φ 4 mm, Upper wiring		
CJ AX21DCE-1	DC:5 to 30V							5 to 40mA	—
BM AZ201CE-1		DC:5 to 30V	5 to 40mA	—	Provided	LED (Lights in red when sensing)	0.3 mm <sup>2</sup> , 2-core, outer dia. φ 4 mm, Upper wiring		
BN AZ205CE-1	DC:5 to 30V							5 to 40mA	—
CM AZ211CE-1		DC:5 to 30V	5 to 40mA	—	Provided	LED (Lights in red when sensing)	0.3 mm <sup>2</sup> , 2-core, outer dia. φ 4 mm, Upper wiring		
CN AZ215CE-1	DC:5 to 30V							5 to 40mA	—
RA AX205WCE		DC:5 to 30V	5 to 40mA	—	Provided	LED (Lights in red when sensing)	0.3 mm <sup>2</sup> , 2-core, outer dia. φ 4 mm, Rear wiring		
RB AZ205WCE	DC:5 to 30V							5 to 40mA	—
RE AX215WCE		DC:5 to 30V	5 to 40mA	—	Provided	LED (Lights in red when sensing)	0.3 mm <sup>2</sup> , 2-core, outer dia. φ 4 mm, Rear wiring		
RF AZ215WCE	DC:5 to 30V							5 to 40mA	—
2 WS215-1		DC:10 to 30V	5 to 20mA	—	Provided	LED (2-LED type in red/green)	0.3 mm <sup>2</sup> , 2-core, outer dia. φ 4 mm Rear wiring		
4 WS215-1F	DC:10 to 30V							5 to 20mA	—
3 WS225-1		DC:5 to 30V	5 to 40mA	—	Provided	LED (2-LED type in red/green)	0.3 mm <sup>2</sup> , 2-core, outer dia. φ 4 mm Rear wiring		
CT AX211CE-1	DC:5 to 30V							5 to 40mA	—
CU AX215CE-1		DC:5 to 30V	5 to 40mA	—	Provided	LED (2-LED type in red/green)	0.3 mm <sup>2</sup> , 2-core, outer dia. φ 4 mm Rear wiring		
CV AX21BCE-1	DC:5 to 30V							5 to 40mA	—
CW AZ211CE-1		DC:5 to 30V	5 to 40mA	—	Provided	LED (2-LED type in red/green)	0.3 mm <sup>2</sup> , 2-core, outer dia. φ 4 mm Upper wiring		
CX AZ215CE-1	DC:5 to 30V							5 to 40mA	—
CY AZ21BCE-1		DC:5 to 30V	5 to 40mA	—	Provided	LED (2-LED type in red/green)	0.3 mm <sup>2</sup> , 2-core, outer dia. φ 4 mm Upper wiring		

Notes) ● For the sensors without a protective circuit, be sure to provide a protective circuit (SK-100) with the load when using any induction load (relay, etc.).  
 ● The output logic of AX and AZ135CE is B contact. When the piston is detected, the sensor contact turns off (the lamp turns on).  
 ● For the details of sensors, be sure to read the sensor specifications at the end of this catalog.  
 ● We recommend AND Unit (AU series) for multiple sensors connected in series. For details, refer to AND Unit at the end of this catalog.

- Standard type  
 AX type (rear wiring)  
 AZ type (upper wiring)
- Cutting oil proof type  
 WR/WS type sensor
- When ordering the cutting oil proof type sensors, WR and WS types, please be carefully the following notification.
  - 5 WR505 The sensor and straight box connector (F-SB) are
  - 2 WS215-1 combined (the flexible tube (F-0.5: 4.8 m) is required).
  - 7 WR505F The flexible tube (F-0.5: 4.8 m) is attached to the
  - 4 WS215-1F sensor and straight box connector (F-SB).



### Mounting Style

The codes in the < > marks below are names called in ISO 10762.

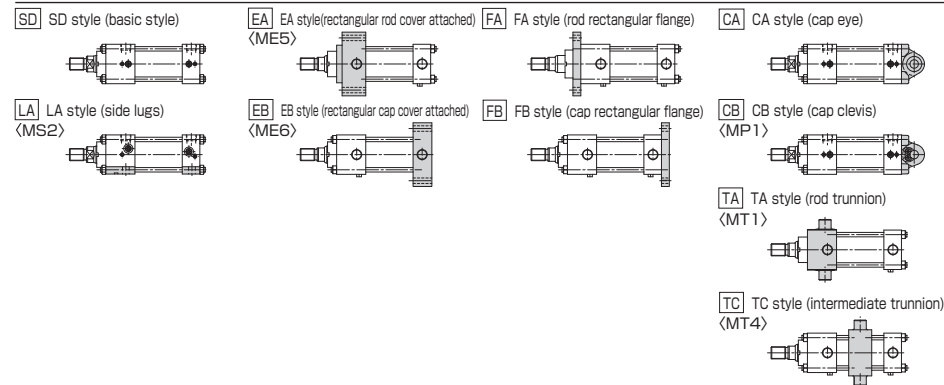

(Note) SD, FA and FB styles are not included in ISO standards.

### Adaptability of Fluid to Seal Material

Seal material	Adaptable fluid				
	Petroleum-based fluid	Water-glycol fluid	Phosphate ester fluid	Water in oil fluid	Oil in water fluid
① Nitrile rubber	○	○	×	○	○
② Urethane rubber	◎	×	×	△	△
③ HNBR	○	◎	×	◎	◎
④ Combined seal	○	○	×	○	○

●◎○: Applicable ×: Inapplicable

● Consult us before using the △-marked items.

● The ◎-marked items are recommended seal materials in case of giving the first priority to abrasion resistance.

● For the working temperature range, refer to the selection materials.

### Seal Structure and Selection Guidelines

Seal code	Adaptable fluid			
	1	2	6	8
Type name	Nitrile rubber type	Urethane rubber type	HNBR type	Combined seal type
Piston seal				
Rod seal and wiper ring				
Fixed part (O-ring, etc.)	Nitrile rubber	Nitrile rubber	HNBR	Nitrile rubber

### Sensor Mountable Minimum Stroke

Mounting Style	Styles other than TC		TC style	
	AX type AX205W	WR/WS type	AX type AX205W	WR/WS type
φ32	30 (40)	55 (75)	115	170
φ40	30	55	115	170
φ50	30	55	125	175
φ63	30	55	130	180
φ80	30	55	140	190
φ100	25	50	150	200
φ125	20	50	160	210

● The parenthesized values in the φ32 row are the minimum strokes when the rod side detection sensor and the cap side detection sensor are mounted on the same surface.

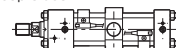

#### Notes

● The minimum stroke is identical whether only one sensor (one-side stroke end detector) or two sensors (double end detector) mounted.

● For the TC style, the values are applicable when the TC accessory is in the center, and the sensor can be installed to any of the rod and cap sides.

### ★ Port position and cushion valve position

- Standard: with cushions on both ends  
Standard port position and cushion valve position

Mounting style	Order symbol		Rod cover		Cap cover	
	Port position	Valve position	Port position	Valve position	Port position	Valve position
SD·LA·CA·CB·FA·FB·TC	A (B·C·D)	B (C·D·A)	A (B·C·D)	B (C·D·A)	A (B·C·D)	B (C·D·A)
EB	A	B	A	B	A	C
EA·TA	A	C	A	C	A	B

- The standard positions of port and cushion valve for styles other than EA, EB and TA are ① and ②, respectively. When modifying the positions, enter the symbol shown in the dimensional drawings.

(Example)

100H-2R 2CA50BB100-B A AH2

Port position (A, B, C, D)

Cushion valve position (A, B, C, D, O)

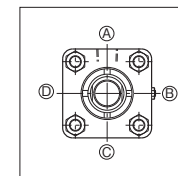

- Specification of change in the positions of cap side port and cushion valve

(Example)

100H-2 2CA50BB100-AB-X PPC

Rod side port and cushion valve positions

Cap side port and cushion position change specification symbol

Position specification : PC-BA

Rod side port and cushion valve positions

- Order symbols and port and cushion valve positions shown above are applicable to EA, EB and TA styles. When modifying the position, specify the position on the rod and cap sides. As for the TA style rod cover, neither port nor cushion valve can be provided on the ③ or ④ side. As for the EA style rod cover, cushion valves cannot be provided on the ③ or ④ side. As for the EB style cap cover, cushion valves cannot be provided on the ③ or ④ side.
- In case that the cylinder is not equipped, the cushion valve position is "O".
- If the ports are located on the ③ or ④ side of the LA style cylinder and general piping joints are used, they may interfere with the cylinder mounting bolts.
- Air vents are located on the same side as the cushion valves. If the cylinder has no cushion, they are located on the ③ side (or ④ side in case of the EA or TA style rod cover).

### ★ Port G thread type

- For the port G thread type, add "G" ahead of the port position symbol.

(Example)

100H-2 2CA50BB100-G A B

Port G thread type

Port position

Cushion valve position

(Note) For cylinders with 32 mm bore, the rod cover size is changed. For details, contact us.

### ★ Notes on ordering cylinder with lock nut

- The rod end thread length (dimension A) is longer when a lock nut  $\boxed{K}$  is attached to the rod end.

(Example)

100H-2R 2LA50BB200-ABAH2- $\boxed{K}$   
Long thread with lock nut

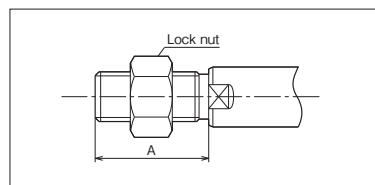

Dimension A without lock nut  
A=28

↓  
Dimension A of long thread with lock nut  
A=40

Note) When a lock nut is attached to the rod end, dimension A must be equal to or longer than that of the long thread with lock nut. For details, refer to "Thread length of rod end with lock nut."

### ★ Delivery of rod end attachment (T-end or Y-end)

A delivery method for a cylinder provided with a lock nut and a rod end attachment differs from that for a cylinder provided with a rod end attachment only (without a lock nut). For details, refer to the dimensional drawings of rod end attachments.

- When the lock nut and rod end attachment are additionally ordered

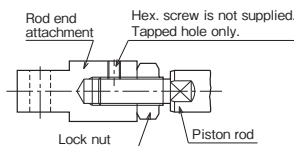

- When only the rod end attachment is additionally ordered (without lock nut)

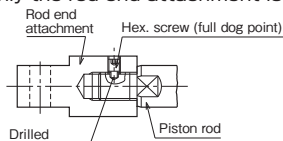

### ★ Semi-standard range

- Change in piston rod end (dimensional symbol: WF (W), A, KK)
- Plated cylinder tube (hard chrome plating thickness: 0.02 mm)
- With boots

### Weight Table

Unit: kg

Bore (mm)	Basic weight (SD style)		Additional weight per mm of stroke		Mounting accessory weight								Rod end attachment weight			
	Single rod type	Double rod type	Single rod type	Double rod type	LA	EA	EB	FA	FB	CA	CB	TA	TC	Rod eye (T-end)	Rod clevis (Y-end)	Lock nut
φ32	1.31	1.73	0.0062	0.0082	0.26	0.34	0.23	0.32	0.28	0.15	0.19	0.04	0.16	0.31	0.38	0.03
φ40	1.96	2.50	0.0062	0.0092	0.24	0.43	0.43	0.45	0.37	0.22	0.29	0.06	0.56	0.38	0.54	0.03
φ50	3.18	4.06	0.0103	0.0151	0.25	0.64	0.62	0.75	0.68	0.31	0.36	0.11	0.97	0.50	0.62	0.05
φ63	4.99	6.32	0.0144	0.0224	0.32	0.72	0.91	1.26	1.11	0.88	1.07	0.22	1.39	1.25	1.86	0.09
φ80	8.65	11.24	0.0227	0.0351	0.68	1.26	1.33	2.16	1.86	1.22	1.40	0.49	2.66	1.66	2.08	0.13
φ100	14.27	17.66	0.0362	0.0554	1.13	1.31	1.99	3.15	2.81	2.15	2.65	0.82	3.85	2.98	3.98	0.23
φ125	22.91	28.22	0.0547	0.0848	1.40	1.51	2.86	5.53	4.98	4.88	6.09	1.30	6.97	6.78	9.25	0.31

### Sensor Additional Weight

Unit: kg

Sensor Bore (mm)	AX type			WR/WS type
	Cord length 1.5 m	Cord length 5 m	Connector type	
φ32 to φ80	0.05	0.13	0.04	0.5
φ100 to φ125	0.07	0.15	0.06	0.5

**Calculation formula** Cylinder weight (kg)=basic weight+(cylinder stroke (mm)×additional weight per mm of stroke)+mounting accessory weight+rod end attachment weight+(sensor additional weight×sensor quantity)

**Calculation example** 100H-2R, bore φ80, cylinder stroke 200 mm, LA style, 2 pcs of AX215  
8.65+(0.0227×200)+0.68+(0.13×2)=14.13kg

100H-2/TQH2 B CAD/DATA is available.

### SD

100H-2 2 SD Bore B Stroke - A B

Port G thread type

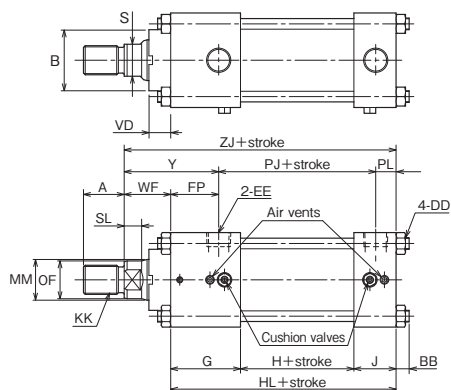
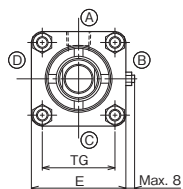
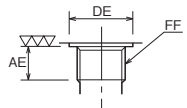

### Double acting double rod

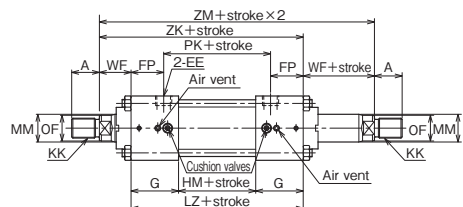

- The distance between the covers of the double rod cylinder is longer than that of the single rod cylinder by 10 mm.

- The positions of cushion valves and air vents depend on the cylinder bore.
- Rod end thread length (dimension A) is longer when a lock nut is attached to the rod end. Refer to "Thread length of rod end with lock nut" in "Rod End Attachment."
- When using the SD style, be sure to see "4. Mounting" in "Precautions for use" at the beginning of this catalog.
- If you want to change the rod protrusion length, specify dimension WF.

### With Boots

100H-2/TQH2 Bore K

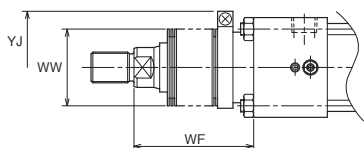

	Standard	Semi-standard	
Material	Nylon tarpaulin	Chloroprene	Conex
Heat proof	80°C	130°C	200°C

Notes)

- Remember that the heat proof field in the table above shows the allowable temperatures for the boots, not for the cylinder.
- Conex is the registered trademark of Teijin Limited.
- The boots have been mounted at our factory prior to delivery.

### Dimension WF

Nylon tarpaulin	{	φ32·φ40	1/3 stroke+X
Chloroprene		φ50	1/3.5 stroke+X
		φ63 to φ100	1/4 stroke+X
		φ125	1/5 stroke+X
Conex	{	φ32	1/2 stroke+X
		φ40·φ50	1/2.5 stroke+X
		φ63 to φ100	1/3 stroke+X
		φ125	1/3.5 stroke+X

- If the calculated WF has a fractional part, round it up.

### Dimensional Table

Symbol Bore	A	B		KK	MM	OF	S	SL	VD
		Standard type	Cutting oil proof type						
φ32	18	φ30f9	φ34f9	M14 × 1.5	φ18	φ17	14	10	10
φ40	22	φ34f9	φ40f9	M16 × 1.5	φ22	φ21	17	9	12
φ50	28	φ42f9	φ46f9	M20 × 1.5	φ28	φ26	22	11	15
φ63	36	φ50f9	φ55f9	M27 × 2	φ36	φ34	30	14	15
φ80	45	φ60f9	φ65f9	M33 × 2	φ45	φ43	38	17	8
φ100	56	φ72f9	—	M42 × 2	φ56	φ54	50	21	16
φ125	63	φ88f9	—	M48 × 2	φ70	φ68	60	24	13

Symbol Bore	AE	BB	DD	DE	E	EE	FF	FP	G	H	HL
φ32	12 Notes)	7	M6 × 1	φ21.5	□45	Rc1/4	G1/4	35	49	28	103
φ40	12	7	M6 × 1	φ25.5	□52	Rc3/8	G3/8	33	48	28	105
φ50	12	9	M8 × 1	φ25.5	□65	Rc3/8	G3/8	33	48	28	105
φ63	14	9	M8 × 1	φ30 or more	□76	Rc1/2	G1/2	35	53	30	117
φ80	14	11	M10 × 1.25	φ30 or more	□94	Rc1/2	G1/2	42	62	34	131
φ100	16	14	M14 × 1.5	φ36.9 or more	□114	Rc3/4	G3/4	38	61	40	143
φ125	16	16	M16 × 1.5	φ36.9 or more	□140	Rc3/4	G3/4	39	62	47	151

Symbol Bore	HM	J	LZ	PJ	PK	PL	TG	WF	Y	ZJ	ZK	ZM
φ32	38	26	136	56	66	12	□33.2	25	60	128	161	186
φ40	38	29	134	58	68	14	□40	25	58	130	159	184
φ50	38	29	134	58	68	14	□50	32	65	137	166	198
φ63	40	34	146	66	76	16	□58	34	69	151	180	214
φ80	44	35	168	74	84	15	□75	35	77	166	203	238
φ100	50	42	172	86	96	19	□90	41	79	184	213	254
φ125	57	42	181	93	103	19	□112	41	80	192	222	263

- Notes) • The 32 mm bore cylinder with G thread port has a thread length adjusting spacer on the rod side.  
• The tolerance of MM is f8.

### With Boots

Symbol Bore	φ32	φ40	φ50	φ63	φ80	φ100	φ125
WW	φ40	φ50	φ50	φ71	φ80	φ100	φ100
X	56	56	58	71	73	75	89
YJ	φ65	φ70	φ75	φ83	φ93	φ105	φ120

CAD/DATA is available. 

### LA

100H-2 [2] LA Bore B B Stroke - [A] [B]

Port G thread type

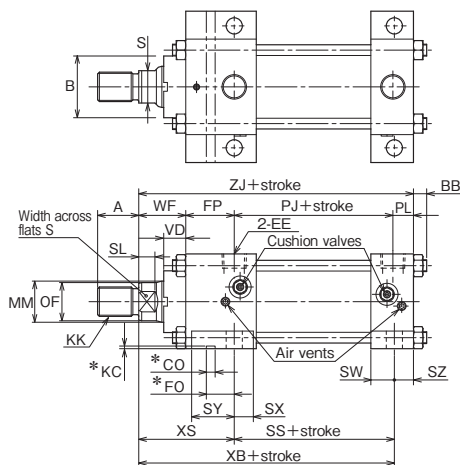
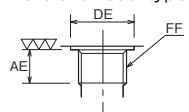

Double acting double rod

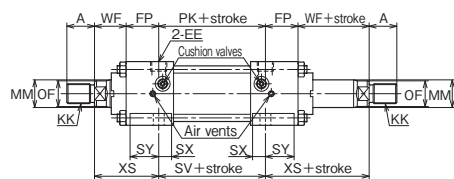

- The positions of cushion valves and air vents depend on the cylinder bore.
- Rod end thread length (dimension A) is longer when a lock nut is attached to the rod end. Refer to "Thread length of rod end with lock nut" in "Rod End Attachment."
- Notes on mounting bolts  
Use hex. socket head cap screws as the mounting bolts for cylinders other than the 32 mm bore cylinder.  
If hex. head bolts are used, bolt heads may interfere with the cover and spot facing, causing mounting failure.
- \*CO, FO and KC are key groove (option) dimensions.
- If you want to change the rod protrusion length, specify dimension WF.

- The distance between the covers of the double rod cylinder is longer than that of the single rod cylinder by 10 mm.

### With Boots

100H-2/TQH2 [Bore] K 

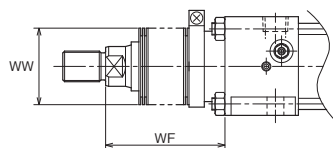

	Standard	Semi-standard	
Material	Nylon tarpaulin	Chloroprene	Conex
Heat proof	80°C	130°C	200°C

#### Notes)

- Remember that the heat proof field in the table above shows the allowable temperatures for the boots, not for the cylinder.
- Conex is the registered trademark of Teijin Limited.
- The boots have been mounted at our factory prior to delivery.

### Dimension WF

Nylon tarpaulin Chloroprene

$\phi 32 \cdot \phi 40$	1/3 stroke+X
$\phi 50$	1/3.5 stroke+X
$\phi 63$ to $\phi 100$	1/4 stroke+X
$\phi 125$	1/5 stroke+X

Conex

$\phi 32$	1/2 stroke+X
$\phi 40 \cdot \phi 50$	1/2.5 stroke+X
$\phi 63$ to $\phi 100$	1/3 stroke+X
$\phi 125$	1/3.5 stroke+X

- If the calculated WF has a fractional part, round it up.

### Notes on LA style with ports on lateral side (B or D)

- The port G thread type is not the standard type. (The position on A or C is the same as that of the standard type.)
- The port position deviates from the cylinder center by dimension LE.
- Take into consideration the interference of the piping and fitting with the mounting bolts (including handling of tightening tools), referring to the table on the right.
- When the cylinder bore is 32 mm, mounting with hex. head bolts is recommended.
- When the cylinder bore is 40 mm or more, hex. head bolts cannot be used. (because their heads interfere with the cover and spot facing). In such a case, use hex. socket head cap screws, and mount the cylinder by tightening nuts on the back of the mounting plate (refer to the drawing on the right).

Symbol Bore	Port EE	LE	LP	Mounting bolt M	Spot facing dia. SE	P Note 1
$\phi 32$	1/4	5.5	15	8	18	20
$\phi 40$	3/8	6.5	20	10	18	20
$\phi 50$	3/8	10	30	10	18	20
$\phi 63$	1/2	11	37	10	19	20
$\phi 80$	1/2	14	43.5	12	24	27
$\phi 100$	3/4	16	48	16	28	33
$\phi 125$	3/4	20	58.5	20	32	38

Note 1) Dimension P must be determined in consideration of interference of the fitting with the mounting bolts.

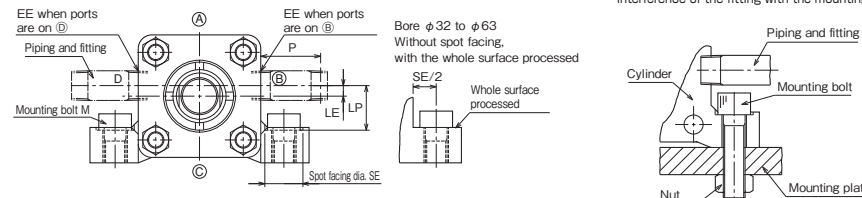

### Dimensional Table

Symbol Bore	A	B		KK	MM	OF	S	SL	VD
		Standard type	Cutting oil proof type						
$\phi 32$	18	$\phi 30f9$	$\phi 34f9$	M14 × 1.5	$\phi 18$	$\phi 17$	14	10	10
$\phi 40$	22	$\phi 34f9$	$\phi 40f9$	M16 × 1.5	$\phi 22$	$\phi 21$	17	9	12
$\phi 50$	28	$\phi 42f9$	$\phi 46f9$	M20 × 1.5	$\phi 28$	$\phi 26$	22	11	15
$\phi 63$	36	$\phi 50f9$	$\phi 55f9$	M27 × 2	$\phi 36$	$\phi 34$	30	14	15
$\phi 80$	45	$\phi 60f9$	$\phi 65f9$	M33 × 2	$\phi 45$	$\phi 43$	38	17	8
$\phi 100$	56	$\phi 72f9$	-	M42 × 2	$\phi 56$	$\phi 54$	50	21	16
$\phi 125$	63	$\phi 88f9$	-	M48 × 2	$\phi 70$	$\phi 68$	60	24	13

Symbol Bore	AE	BB	DE	E	EE	EH	FF	FP	LH	PJ	PK	PL	SB	SS	ST	SV	SW	SX	SY	SZ	TS	US	WF
$\phi 32$	12(Notes)	7	$\phi 21.5$	45	Rc1/4	44.5	G1/4	35	22h10	56	66	12	$\phi 9$	73	12.5	96	16	29	20	10	63	84	25
$\phi 40$	12	7	$\phi 25.5$	52	Rc3/8	51.5	G3/8	33	25.5h10	58	68	14	$\phi 11$	59	12	68	16	15	33	13	70	90	25
$\phi 50$	12	9	$\phi 25.5$	65	Rc3/8	64.5	G3/8	33	32h10	58	68	14	$\phi 11$	59	12	68	16	15	33	13	83	103	32
$\phi 63$	14	9	$\phi 30$ or more	76	Rc1/2	76	G1/2	35	38h10	66	76	16	$\phi 11$	68	12	78	19	19	34	15	95	115	34
$\phi 80$	14	11	$\phi 30$ or more	94	Rc1/2	94.5	G1/2	42	47.5h10	74	84	15	$\phi 14$	74	18	84	20	17	39	13	121	147	35
$\phi 100$	16	14	$\phi 36.3$ or more	114	Rc3/4	114	G3/4	38	57h10	86	96	19	$\phi 18$	86	25	96	23	20	35	16	145	179	41
$\phi 125$	16	16	$\phi 36.3$ or more	140	Rc3/4	139.5	G3/4	39	69.5h10	93	103	19	$\phi 22$	95	31	105	24	21	35	17	175	216	41

### Key groove (option)

Symbol Bore	XB	XS	ZJ	CO	FO	KC
$\phi 32$	118	45	128	6N9	14	1.8 +0.3/0
$\phi 40$	117	58	130	6N9	18	1.8 +0.3/0
$\phi 50$	124	65	137	6N9	19	1.8 +0.3/0
$\phi 63$	136	68	151	12N9	21	3.3 +0.3/0
$\phi 80$	151	77	166	14N9	30	3.8 +0.3/0
$\phi 100$	165	79	184	14N9	30	3.8 +0.3/0
$\phi 125$	174	79	192	14N9	30	3.8 +0.3/0

- Notes) • The 32 mm bore cylinder with G thread port has a thread length adjusting spacer on the rod side.
- The tolerance of MM is f8.

### With Boots

Symbol Bore	$\phi 32$	$\phi 40$	$\phi 50$	$\phi 63$	$\phi 80$	$\phi 100$	$\phi 125$
WW	$\phi 40$	$\phi 50$	$\phi 50$	$\phi 71$	$\phi 80$	$\phi 100$	$\phi 100$
X	56	56	58	71	73	75	89

100H-2/TQH2 [Bore]B CAD/DATA is available.

### EA

100H-2 2 EA Bore B B Stroke - A C

Port G thread type

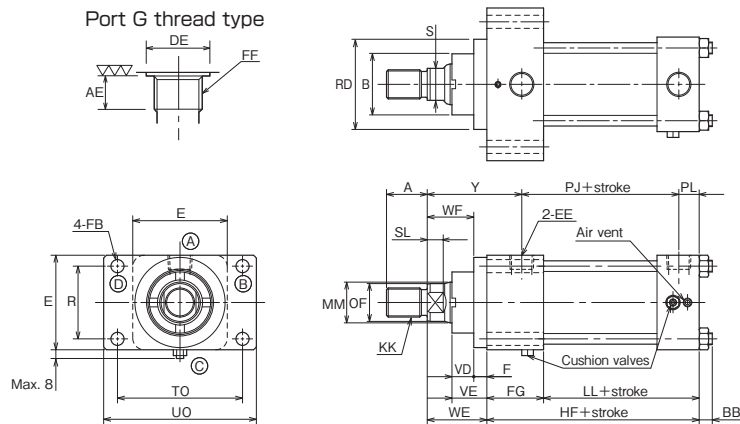

- The positions of cushion valves and air vents depend on the cylinder bore.
- Rod end thread length (dimension A) is longer when a lock nut is attached to the rod end. Refer to "Thread length of rod end with lock nut" in "Rod End Attachment."
- If the mounting plate is located on the cylinder tube side of the Switch Set Cylinder, take into consideration the interference of the sensor with the mounting plate.
- If you want to change the rod protrusion length, specify dimension WF.
- The symbols (A) and (C) shown in the above figure indicate the standard positions of port and cushion valve (Rod side: (A)(C), Cap side: (A)(B)). When changing any position, be sure to specify the port or cushion valve positions on the rod and cap sides.

### Double acting double rod

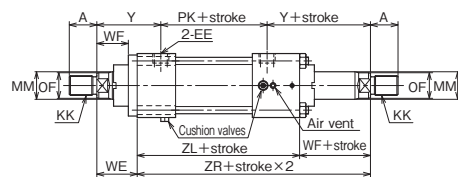

- The distance between the covers of the double rod cylinder is longer than that of the single rod cylinder by 10 mm.

### With Boots

100H-2/TQH2 [Bore]K

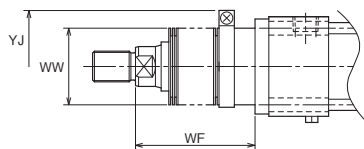

### Dimension WF

Material	Stroke	WF
Nylon tarpaulin Chloroprene	φ32 · φ40	1/3 stroke + X
	φ50	1/3.5 stroke + X
	φ63 to φ100	1/4 stroke + X
	φ125	1/5 stroke + X
Conex	φ32	1/2 stroke + X
	φ40 · φ50	1/2.5 stroke + X
	φ63 to φ100	1/3 stroke + X
	φ125	1/3.5 stroke + X

- If the calculated WF has a fractional part, round it up.

	Standard	Semi-standard	
Material	Nylon tarpaulin	Chloroprene	Conex
Heat proof	80°C	130°C	200°C

### Notes

- Remember that the heat proof field in the table above shows the allowable temperatures for the boots, not for the cylinder.
- Conex is the registered trademark of Teijin Limited.
- The boots have been mounted at our factory prior to delivery.

### Dimensional Table

Symbol Bore	A	B		KK	MM	OF	RD	S	SL	VD	VE
		Standard type	Cutting oil proof type								
φ32	18	φ30f9	φ34f9	M14 × 1.5	φ18	φ17	φ42f8	14	10	10	20
φ40	22	φ34f9	φ40f9	M16 × 1.5	φ22	φ21	φ51f8	17	9	12	22
φ50	28	φ42f9	φ46f9	M20 × 1.5	φ28	φ26	φ62f8	22	11	15	24
φ63	36	φ50f9	φ55f9	M27 × 2	φ36	φ34	φ72f8	30	14	15	29
φ80	45	φ60f9	φ65f9	M33 × 2	φ45	φ43	φ92f8	38	17	8	24
φ100	56	φ72f9	—	M42 × 2	φ56	φ54	φ110f8	50	21	16	32
φ125	63	φ88f9	—	M48 × 2	φ70	φ68	φ130f8	60	24	13	29

Symbol Bore	AE	BB	DE	E	EE	F	FB	FF	FG	HF	LL
φ32	12	7	φ21.5	□45	Rc1/4	10	φ6.6	G1/4	39	93	54
φ40	12	7	φ25.5	□52	Rc3/8	10	φ6.6	G3/8	38	95	57
φ50	12	9	φ25.5	□65	Rc3/8	9	φ9	G3/8	39	96	57
φ63	14	9	φ30 or more	□76	Rc1/2	14 (Note 1)	φ9	G1/2	39	103	64
φ80	14	11	φ30 or more	□94	Rc1/2	16	φ11	G1/2	46	115	69
φ100	16	14	φ36.9 or more	□114	Rc3/4	16	φ13.5	G3/4	45	127	82
φ125	16	16	φ36.9 or more	□140	Rc3/4	16	φ17.5	G3/4	46	135	89

Symbol Bore	PJ	PK	PL	R	TO	UO	WE	WF	Y	ZL	ZR
φ32	56	66	12	33	58	70	35	25	60	126	151
φ40	58	68	14	40	70	86	35	25	58	124	149
φ50	58	68	14	50	86	105	41	32	65	125	157
φ63	66	76	16	56	98	118	48	34	69	132	166
φ80	74	84	15	70	119	142	51	35	77	152	187
φ100	86	96	19	90	138	161	57	41	79	156	197
φ125	93	103	19	110	168	194	57	41	80	165	206

- Note 1) • Up to 10 according to the standard (JIS B8367-5)  
• The tolerance of MM is f8.

### With Boots

Symbol Bore	φ32	φ40	φ50	φ63	φ80	φ100	φ125
WW	φ40	φ50	φ50	φ71	φ80	φ100	φ100
XX	56	56	58	71	73	75	89
YJ	φ65	φ70	φ75	φ83	φ93	φ105	φ120

100H-2/TQH2 [Bore]B CAD/DATA is available.

### EB

100H-2 2 EB Bore B B Stroke - A B

Port G thread type

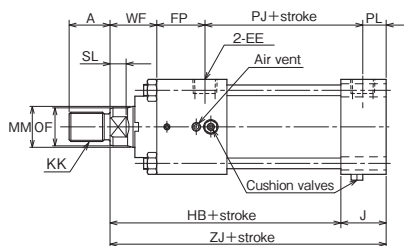
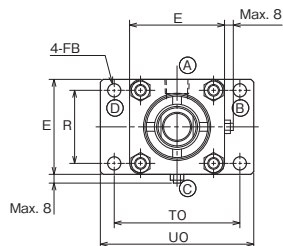
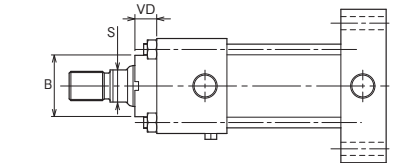
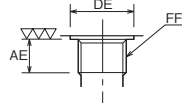

- The positions of cushion valves and air vents depend on the cylinder bore.
- Rod end thread length (dimension A) is longer when a lock nut is attached to the rod end. Refer to "Thread length of rod end with lock nut" in "Rod End Attachment."
- If the mounting plate is located on the cylinder tube side of the Switch Set Cylinder, take into consideration the interference of the sensor with the mounting plate.
- If you want to change the rod protrusion length, specify dimension WF.

- The symbols (A) and (B) shown in the above figure indicate the standard positions of port and cushion valve (Rod side: (A)(B), Cap side: (A)(C)). When changing any position, be sure to specify the port or cushion valve positions on the rod and cap sides.

### With Boots

100H-2/TQH2 [Bore]K

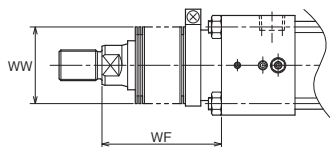

	Standard	Semi-standard	
Material	Nylon tarpaulin	Chloroprene	Conex
Heat proof	80°C	130°C	200°C

Notes)

- Remember that the heat proof field in the table above shows the allowable temperatures for the boots, not for the cylinder.
- Conex is the registered trademark of Teijin Limited.
- The boots have been mounted at our factory prior to delivery.

### Dimension WF

Nylon tarpaulin Chloroprene	$\phi 32 \cdot \phi 40$	1/3 stroke+X
	$\phi 50$	1/3.5 stroke+X
	$\phi 63$ to $\phi 100$	1/4 stroke+X
	$\phi 125$	1/5 stroke+X
Conex	$\phi 32$	1/2 stroke+X
	$\phi 40 \cdot \phi 50$	1/2.5 stroke+X
	$\phi 63$ to $\phi 100$	1/3 stroke+X
	$\phi 125$	1/3.5 stroke+X

- If the calculated WF has a fractional part, round it up.

### Dimensional Table

Symbol Bore	A	B		KK	MM	OF	S	SL	VD
		Standard type	Cutting oil proof type						
$\phi 32$	18	$\phi 30f9$	$\phi 34f9$	M14×1.5	$\phi 18$	$\phi 17$	14	10	10
$\phi 40$	22	$\phi 34f9$	$\phi 40f9$	M16×1.5	$\phi 22$	$\phi 21$	17	9	12
$\phi 50$	28	$\phi 42f9$	$\phi 46f9$	M20×1.5	$\phi 28$	$\phi 26$	22	11	15
$\phi 63$	36	$\phi 50f9$	$\phi 55f9$	M27×2	$\phi 36$	$\phi 34$	30	14	15
$\phi 80$	45	$\phi 60f9$	$\phi 65f9$	M33×2	$\phi 45$	$\phi 43$	38	17	8
$\phi 100$	56	$\phi 72f9$	—	M42×2	$\phi 56$	$\phi 54$	50	21	16
$\phi 125$	63	$\phi 88f9$	—	M48×2	$\phi 70$	$\phi 68$	60	24	13

Symbol Bore	AE	DE	E	EE	FB	FF	FP	HB	J	PJ	PL
$\phi 32$	12	$\phi 21.5$	$\square 45$	Rc1/4	$\phi 6.6$	G1/4	35	102	26	56	12
$\phi 40$	12	$\phi 25.5$	$\square 52$	Rc3/8	$\phi 6.6$	G3/8	33	101	31	58	16
$\phi 50$	12	$\phi 25.5$	$\square 65$	Rc3/8	$\phi 9$	G3/8	33	108	31	58	16
$\phi 63$	14	$\phi 30$ or more	$\square 76$	Rc1/2	$\phi 9$	G1/2	35	117	36	66	18
$\phi 80$	14	$\phi 30$ or more	$\square 94$	Rc1/2	$\phi 11$	G1/2	42	131	37	74	17
$\phi 100$	16	$\phi 36.9$ or more	$\square 114$	Rc3/4	$\phi 13.5$	G3/4	38	142	45	86	22
$\phi 125$	16	$\phi 36.9$ or more	$\square 140$	Rc3/4	$\phi 17.5$	G3/4	39	150	46	93	23

Symbol Bore	R	TO	UO	WF	ZJ
$\phi 32$	33	58	70	25	128
$\phi 40$	40	70	86	25	132
$\phi 50$	50	86	105	32	139
$\phi 63$	56	98	118	34	153
$\phi 80$	70	119	142	35	168
$\phi 100$	90	138	161	41	187
$\phi 125$	110	168	194	41	196

- The tolerance of MM is f8.

### With Boots

Symbol Bore	$\phi 32$	$\phi 40$	$\phi 50$	$\phi 63$	$\phi 80$	$\phi 100$	$\phi 125$
WW	$\phi 40$	$\phi 50$	$\phi 50$	$\phi 71$	$\phi 80$	$\phi 100$	$\phi 100$
X	56	56	58	71	73	75	89



CAD/DATA  
100H-2/TQH2 [Bore]B is available. 

## FA

100H-2 2 FA Bore B B Stroke - A B

Port G thread type

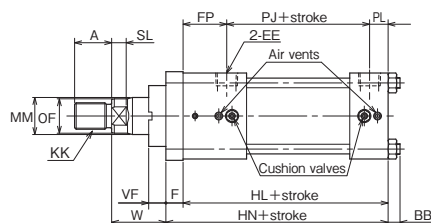
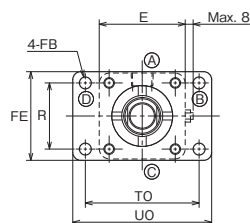
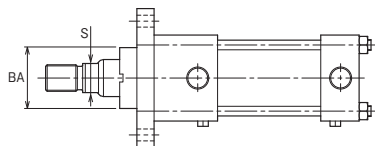
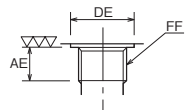

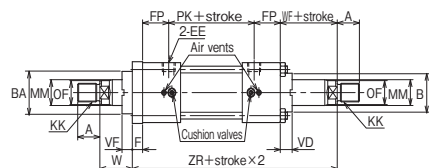

Double acting double rod



- The distance between the covers of the double rod cylinder is longer than that of the single rod cylinder by 10 mm.

- The positions of cushion valves and air vents depend on the cylinder bore.
- Rod end thread length (dimension A) is longer when a lock nut is attached to the rod end. Refer to "Thread length of rod end with lock nut" in "Rod End Attachment."
- If you want to change the rod protrusion length, specify dimension W.

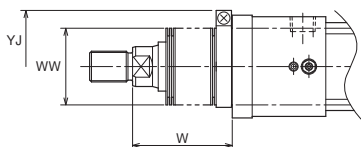
## With Boots

100H-2/TQH2 [Bore]K 

## Dimension W

Nylon tarpaulin  
Chloroprene

$\phi 32 \cdot \phi 40$	$1/3 \text{ stroke} + X$
$\phi 50$	$1/3.5 \text{ stroke} + X$
$\phi 63 \text{ to } \phi 100$	$1/4 \text{ stroke} + X$
$\phi 125$	$1/5 \text{ stroke} + X$

Conex

$\phi 32$	$1/2 \text{ stroke} + X$
$\phi 40 \cdot \phi 50$	$1/2.5 \text{ stroke} + X$
$\phi 63 \text{ to } \phi 100$	$1/3 \text{ stroke} + X$
$\phi 125$	$1/3.5 \text{ stroke} + X$

- If the calculated W has a fractional part, round it up.

	Standard	Semi-standard	
Material	Nylon tarpaulin	Chloroprene	Conex
Heat proof	80°C	130°C	200°C

## Notes)

- Remember that the heat proof field in the table above shows the allowable temperatures for the boots, not for the cylinder.
- Conex is the registered trademark of Teijin Limited.
- The boots have been mounted at our factory prior to delivery.

## Dimensional Table

Symbol Bore	A	B		BA	KK	MM	OF	S	SL	VD	VF
		Standard type	Cutting oil proof type								
$\phi 32$	18	$\phi 30f9$	$\phi 34f9$	$\phi 34f9$	M14 × 1.5	$\phi 18$	$\phi 17$	14	10	10	13
$\phi 40$	22	$\phi 34f9$	$\phi 40f9$	$\phi 40f9$	M16 × 1.5	$\phi 22$	$\phi 21$	17	9	12	13
$\phi 50$	28	$\phi 42f9$	$\phi 46f9$	$\phi 46f9$	M20 × 1.5	$\phi 28$	$\phi 26$	22	11	15	13
$\phi 63$	36	$\phi 50f9$	$\phi 55f9$	$\phi 55f9$	M27 × 2	$\phi 36$	$\phi 34$	30	14	15	13
$\phi 80$	45	$\phi 60f9$	$\phi 65f9$	$\phi 65f9$	M33 × 2	$\phi 45$	$\phi 43$	38	17	8	13
$\phi 100$	56	$\phi 72f9$	—	$\phi 77f9$	M42 × 2	$\phi 56$	$\phi 54$	50	21	16	13
$\phi 125$	63	$\phi 88f9$	—	$\phi 92f9$	M48 × 2	$\phi 70$	$\phi 68$	60	24	13	13

Symbol Bore	AE	BB	DE	E	EE	F	FB	FE	FF	FP	HL	HN
$\phi 32$	12 (Note 1)	7	$\phi 21.5$	$\square 45$	Rc1/4	11	$\phi 6.6$	47	G1/4	35	103	114
$\phi 40$	12	7	$\phi 25.5$	$\square 52$	Rc3/8	11	$\phi 6.6$	54	G3/8	33	105	116
$\phi 50$	12	9	$\phi 25.5$	$\square 65$	Rc3/8	13	$\phi 9$	67	G3/8	33	105	118
$\phi 63$	14	9	$\phi 30$ or more	$\square 76$	Rc1/2	16	$\phi 9$	78	G1/2	35	117	133
$\phi 80$	14	11	$\phi 30$ or more	$\square 94$	Rc1/2	18	$\phi 11$	96	G1/2	42	131	149
$\phi 100$	16	14	$\phi 36.9$ or more	$\square 114$	Rc3/4	20	$\phi 13.5$	116	G3/4	38	143	163
$\phi 125$	16	16	$\phi 36.9$ or more	$\square 140$	Rc3/4	24	$\phi 17.5$	142	G3/4	39	151	175

Symbol Bore	PJ	PK	PL	R	TO	UO	W	WF	ZR
$\phi 32$	56	66	12	33	58	70	35	25	172
$\phi 40$	58	68	14	40	70	86	35	25	170
$\phi 50$	58	68	14	50	86	105	41	32	179
$\phi 63$	66	76	16	56	98	118	48	34	196
$\phi 80$	74	84	15	70	119	143	51	35	221
$\phi 100$	86	96	19	90	138	162	57	41	233
$\phi 125$	93	103	19	110	168	194	57	41	246

- Note 1) • The 32 mm bore cylinder with G thread port has a thread length adjusting spacer on the rod side.  
• The tolerance of MM is f8.

## With Boots

Symbol Bore	$\phi 32$	$\phi 40$	$\phi 50$	$\phi 63$	$\phi 80$	$\phi 100$	$\phi 125$
WW	$\phi 40$	$\phi 50$	$\phi 50$	$\phi 71$	$\phi 80$	$\phi 100$	$\phi 100$
X	45	45	45	55	55	55	65
YJ	$\phi 65$	$\phi 70$	$\phi 75$	$\phi 83$	$\phi 93$	$\phi 105$	$\phi 120$

100H-2/TQH2 [Bore]B CAD/DATA is available.

### FB

100H-2 2 FB Bore B B Stroke - A B

Port G thread type

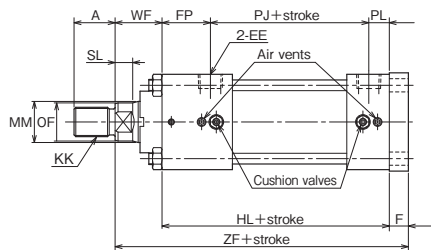
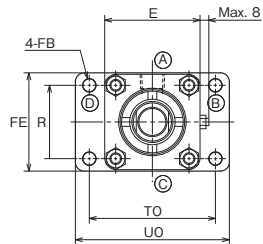
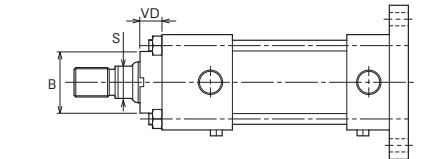
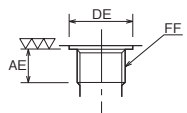

- The positions of cushion valves and air vents depend on the cylinder bore.
- Rod end thread length (dimension A) is longer when a lock nut is attached to the rod end. Refer to "Thread length of rod end with lock nut" in "Rod End Attachment."
- If you want to change the rod protrusion length, specify dimension WF.

- For the G thread type, the FB accessory may interfere with the fitting when the fitting is screwed into the rod side port, depending on the fitting type. Check the size of the fitting to be used referring to dimension PL. Consult us if any interference occurs.

### With Boots

100H-2/TQH2 [Bore]K

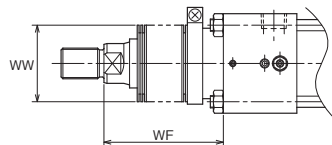

	Standard	Semi-standard	
Material	Nylon tarpaulin	Chloroprene	Conex
Heat proof	80°C	130°C	200°C

Notes)

- Remember that the heat proof field in the table above shows the allowable temperatures for the boots, not for the cylinder.
- Conex is the registered trademark of Teijin Limited.
- The boots have been mounted at our factory prior to delivery.

### Dimension WF

Nylon tarpaulin Chloroprene	φ32·φ40	1/3 stroke+X
	φ50	1/3.5 stroke+X
	φ63 to φ100	1/4 stroke+X
	φ125	1/5 stroke+X
Conex	φ32	1/2 stroke+X
	φ40·φ50	1/2.5 stroke+X
	φ63 to φ100	1/3 stroke+X
	φ125	1/3.5 stroke+X

- If the calculated WF has a fractional part, round it up.

### Dimensional Table

Symbol Bore	A	B		KK	MM	OF	S	SL	VD
		Standard type	Cutting oil proof type						
φ32	18	φ30f9	φ34f9	M14×1.5	φ18	φ17	14	10	10
φ40	22	φ34f9	φ40f9	M16×1.5	φ22	φ21	17	9	12
φ50	28	φ42f9	φ46f9	M20×1.5	φ28	φ26	22	11	15
φ63	36	φ50f9	φ55f9	M27×2	φ36	φ34	30	14	15
φ80	45	φ60f9	φ65f9	M33×2	φ45	φ43	38	17	8
φ100	56	φ72f9	—	M42×2	φ56	φ54	50	21	16
φ125	63	φ88f9	—	M48×2	φ70	φ68	60	24	13

Symbol Bore	AE	DE	E	EE	F	FB	FE	FF	FP	HL	PJ
φ32	12 (Note 1)	φ21.5	□45	Rc1/4	11	φ6.6	47	G1/4	35	103	56
φ40	12	φ25.5	□52	Rc3/8	11	φ6.6	54	G3/8	33	105	58
φ50	12	φ25.5	□65	Rc3/8	13	φ9	67	G3/8	33	105	58
φ63	14	φ30 or more	□76	Rc1/2	16	φ9	78	G1/2	35	117	66
φ80	14	φ30 or more	□94	Rc1/2	18	φ11	96	G1/2	42	131	74
φ100	16	φ36.9 or more	□114	Rc3/4	20	φ13.5	116	G3/4	38	143	86
φ125	16	φ36.9 or more	□140	Rc3/4	24	φ17.5	142	G3/4	39	151	93

Symbol Bore	PL	R	TO	UO	WF	ZF
φ32	12	33	58	70	25	139
φ40	14	40	70	86	25	141
φ50	14	50	86	105	32	150
φ63	16	56	98	118	34	167
φ80	15	70	119	143	35	184
φ100	19	90	138	162	41	204
φ125	19	110	168	194	41	216

- Note 1) • The 32 mm bore cylinder with G thread port has a thread length adjusting spacer on the rod side.  
• The tolerance of MM is f8.

### With Boots

Symbol Bore	φ32	φ40	φ50	φ63	φ80	φ100	φ125
WW	φ40	φ50	φ50	φ71	φ80	φ100	φ100
X	56	56	58	71	73	75	89

100H-2/TQH2 [Bore] B CAD/DATA is available.

### CA

100H-2 2 CA Bore B B Stroke - A B

● Bore  $\phi 40$  to  $\phi 100$

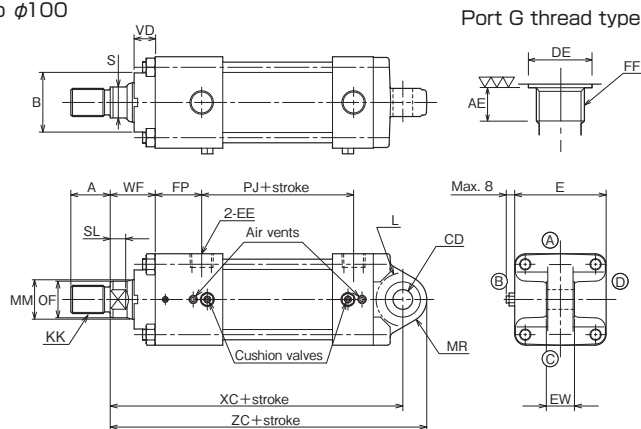

Port G thread type

- The positions of cushion valves and air vents depend on the cylinder bore.
- Rod end thread length (dimension A) is longer when a lock nut is attached to the rod end. Refer to "Thread length of rod end with lock nut" in "Rod End Attachment."
- If you want to change the rod protrusion length, specify dimension WF.

● Bore  $\phi 32 \cdot \phi 125$

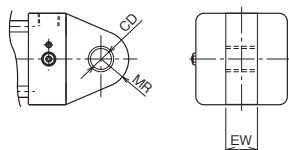

### With Boots

100H-2/TQH2 [Bore] K

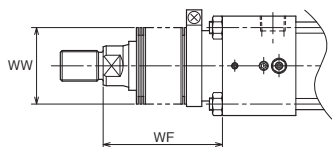

	Standard	Semi-standard	
Material	Nylon tarpaulin	Chloroprene	Conex
Heat proof	80°C	130°C	200°C

#### Notes

- Remember that the heat proof field in the table above shows the allowable temperatures for the boots, not for the cylinder.
- Conex is the registered trademark of Teijin Limited.
- The boots have been mounted at our factory prior to delivery.

#### Dimension WF

Nylon tarpaulin Chloroprene	$\phi 32 \cdot \phi 40$	$1/3 \text{ stroke} + X$
	$\phi 50$	$1/3.5 \text{ stroke} + X$
	$\phi 63$ to $\phi 100$	$1/4 \text{ stroke} + X$
	$\phi 125$	$1/5 \text{ stroke} + X$
Conex	$\phi 32$	$1/2 \text{ stroke} + X$
	$\phi 40 \cdot \phi 50$	$1/2.5 \text{ stroke} + X$
	$\phi 63$ to $\phi 100$	$1/3 \text{ stroke} + X$
	$\phi 125$	$1/3.5 \text{ stroke} + X$

● If the calculated WF has a fractional part, round it up.

### Dimensional Table

Symbol Bore	A	B		KK	MM	OF	S	SL	VD
		Standard type	Cutting oil proof type						
$\phi 32$	18	$\phi 30f9$	$\phi 34f9$	M14×1.5	$\phi 18$	$\phi 17$	14	10	10
$\phi 40$	22	$\phi 34f9$	$\phi 40f9$	M16×1.5	$\phi 22$	$\phi 21$	17	9	12
$\phi 50$	28	$\phi 42f9$	$\phi 46f9$	M20×1.5	$\phi 28$	$\phi 26$	22	11	15
$\phi 63$	36	$\phi 50f9$	$\phi 55f9$	M27×2	$\phi 36$	$\phi 34$	30	14	15
$\phi 80$	45	$\phi 60f9$	$\phi 65f9$	M33×2	$\phi 45$	$\phi 43$	38	17	8
$\phi 100$	56	$\phi 72f9$	—	M42×2	$\phi 56$	$\phi 54$	50	21	16
$\phi 125$	63	$\phi 88f9$	—	M48×2	$\phi 70$	$\phi 68$	60	24	13

Symbol Bore	AE	CD	DE	E	EE	EW	FF	FP	L	MR	PJ	WF
$\phi 32$	12 (Note 1)	$\phi 12H9$	$\phi 21.5$	$\square 45$	Rc1/4	16h14	G1/4	35	R19	R17	56	25
$\phi 40$	12	$\phi 14H9$	$\phi 25.5$	$\square 52$	Rc3/8	20h14	G3/8	33	R19	R17	58	25
$\phi 50$	12	$\phi 14H9$	$\phi 25.5$	$\square 65$	Rc3/8	20h14	G3/8	33	R19	R17	58	32
$\phi 63$	14	$\phi 20H9$	$\phi 30$ or more	$\square 76$	Rc1/2	30h14	G1/2	35	R32	R29	66	34
$\phi 80$	14	$\phi 20H9$	$\phi 30$ or more	$\square 94$	Rc1/2	30h14	G1/2	42	R32	R29	74	35
$\phi 100$	16	$\phi 28H9$	$\phi 36.9$ or more	$\square 114$	Rc3/4	40h14	G3/4	38	R39	R34	86	41
$\phi 125$	16	$\phi 36H9$	$\phi 36.9$ or more	$\square 140$	Rc3/4	50h14	G3/4	39	R54	R50	93	41

Symbol Bore	XC	ZC
$\phi 32$	147	164
$\phi 40$	151	168
$\phi 50$	158	175
$\phi 63$	185	214
$\phi 80$	200	229
$\phi 100$	226	260
$\phi 125$	250	300

- Note 1) ● The 32 mm bore cylinder with G thread port has a thread length adjusting spacer on the rod side.  
● The tolerance of MM is f8.

### With Boots

Symbol Bore	$\phi 32$	$\phi 40$	$\phi 50$	$\phi 63$	$\phi 80$	$\phi 100$	$\phi 125$
WW	$\phi 40$	$\phi 50$	$\phi 50$	$\phi 71$	$\phi 80$	$\phi 100$	$\phi 100$
X	56	56	58	71	73	75	89

100H-2/TQH2 Bore B is available.

### CB

100H-2 2 CB Bore B B Stroke - A B

- Bore  $\phi 63$  to  $\phi 125$

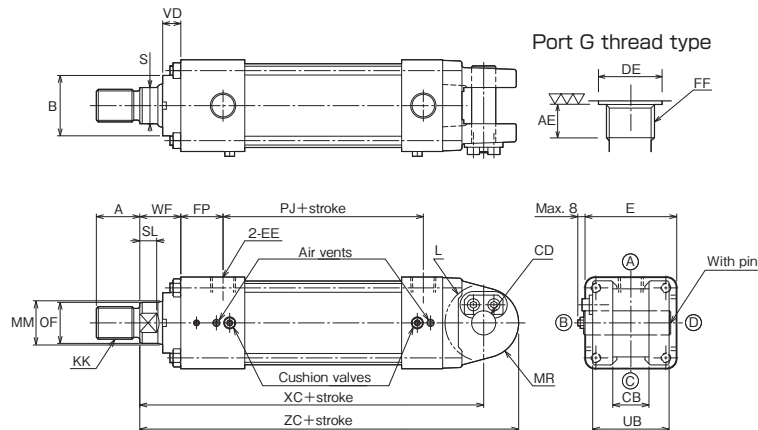

- The positions of cushion valves and air vents depend on the cylinder bore.
- Rod end thread length (dimension A) is longer when a lock nut is attached to the rod end. Refer to "Thread length of rod end with lock nut" in "Rod End Attachment."
- If you want to change the rod protrusion length, specify dimension WF.

#### • Bore $\phi 32$

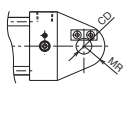

#### • Bore $\phi 40 \cdot \phi 50$

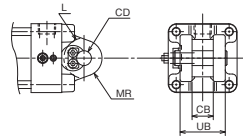

### With Boots

100H-2/TQH2 Bore K

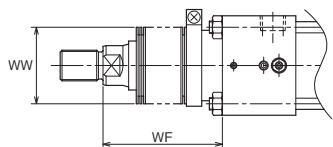

	Standard	Semi-standard	
Material	Nylon tarpaulin	Chloroprene	Conex
Heat proof	80°C	130°C	200°C

- Notes) • Remember that the heat proof field in the table above shows the allowable temperatures for the boots, not for the cylinder.
- Conex is the registered trademark of Teijin Limited.
  - The boots have been mounted at our factory prior to delivery.

#### Dimension WF

Nylon tarpaulin Chloroprene	$\left( \begin{array}{l} \phi 32 \cdot \phi 40 \\ \phi 50 \\ \phi 63 \text{ to } \phi 100 \\ \phi 125 \end{array} \right. \begin{array}{l} 1/3 \text{ stroke} + X \\ 1/3.5 \text{ stroke} + X \\ 1/4 \text{ stroke} + X \\ 1/5 \text{ stroke} + X \end{array} \right)$
Conex	$\left( \begin{array}{l} \phi 32 \\ \phi 40 \cdot \phi 50 \\ \phi 63 \text{ to } \phi 100 \\ \phi 125 \end{array} \right. \begin{array}{l} 1/2 \text{ stroke} + X \\ 1/2.5 \text{ stroke} + X \\ 1/3 \text{ stroke} + X \\ 1/3.5 \text{ stroke} + X \end{array} \right)$

- If the calculated WF has a fractional part, round it up.

### Dimensional Table

Symbol Bore	A	B		KK	MM	OF	S	SL	VD
		Standard type	Cutting oil proof type						
$\phi 32$	18	$\phi 30f9$	$\phi 34f9$	M14 $\times$ 1.5	$\phi 18$	$\phi 17$	14	10	10
$\phi 40$	22	$\phi 34f9$	$\phi 40f9$	M16 $\times$ 1.5	$\phi 22$	$\phi 21$	17	9	12
$\phi 50$	28	$\phi 42f9$	$\phi 46f9$	M20 $\times$ 1.5	$\phi 28$	$\phi 26$	22	11	15
$\phi 63$	36	$\phi 50f9$	$\phi 55f9$	M27 $\times$ 2	$\phi 36$	$\phi 34$	30	14	15
$\phi 80$	45	$\phi 60f9$	$\phi 65f9$	M33 $\times$ 2	$\phi 45$	$\phi 43$	38	17	8
$\phi 100$	56	$\phi 72f9$	—	M42 $\times$ 2	$\phi 56$	$\phi 54$	50	21	16
$\phi 125$	63	$\phi 88f9$	—	M48 $\times$ 2	$\phi 70$	$\phi 68$	60	24	13

Symbol Bore	AE	CB	CD	DE	E	EE	FF	FP	L	MR	PJ
$\phi 32$	12 (Note 1)	16A16	$\phi 12$ H9/f8	$\phi 21.5$	$\square 45$	Rc1/4	G1/4	35	R19	R17	56
$\phi 40$	12	20A16	$\phi 14$ H9/f8	$\phi 25.5$	$\square 52$	Rc3/8	G3/8	33	R19	R17	58
$\phi 50$	12	20A16	$\phi 14$ H9/f8	$\phi 25.5$	$\square 65$	Rc3/8	G3/8	33	R19	R17	58
$\phi 63$	14	30A16	$\phi 20$ H9/f8	$\phi 30$ or more	$\square 76$	Rc1/2	G1/2	35	R32	R29	66
$\phi 80$	14	30A16	$\phi 20$ H9/f8	$\phi 30$ or more	$\square 94$	Rc1/2	G1/2	42	R32	R29	74
$\phi 100$	16	40A16	$\phi 28$ H9/f8	$\phi 36.9$ or more	$\square 114$	Rc3/4	G3/4	38	R39	R34	86
$\phi 125$	16	50A16	$\phi 36$ H9/f8	$\phi 36.9$ or more	$\square 140$	Rc3/4	G3/4	39	R54	R50	93

Symbol Bore	UB	WF	XC	ZC
$\phi 32$	32	25	147	164
$\phi 40$	43	25	151	168
$\phi 50$	43	32	158	175
$\phi 63$	65	34	185	214
$\phi 80$	65	35	200	229
$\phi 100$	83	41	226	260
$\phi 125$	103	41	250	300

- Note 1) • The 32 mm bore cylinder with G thread port has a thread length adjusting spacer on the rod side.  
• The tolerance of MM is f8.

### With Boots

Symbol Bore	$\phi 32$	$\phi 40$	$\phi 50$	$\phi 63$	$\phi 80$	$\phi 100$	$\phi 125$
WW	$\phi 40$	$\phi 50$	$\phi 50$	$\phi 71$	$\phi 80$	$\phi 100$	$\phi 100$
X	56	56	58	71	73	75	89

100H-2/TQH2 [Bore] B CAD/DATA is available.

### TA

100H-2 [2] TA [Bore] B [B] Stroke - [A] [C]

Port G thread type

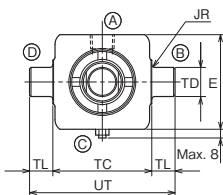
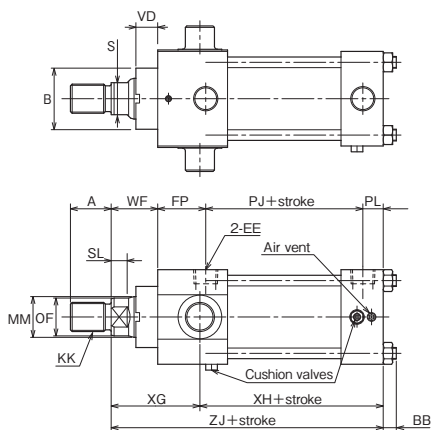
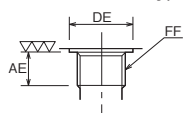

- The positions of cushion valves and air vents depend on the cylinder bore.
- Rod end thread length (dimension A) is longer when a lock nut is attached to the rod end. Refer to "Thread length of rod end with lock nut" in "Rod End Attachment."
- If the stroke is short, take care that the cushion valve does not get into contact with the mounting bracket.
- If you want to change the rod protrusion length, specify dimension WF.

### Double acting double rod

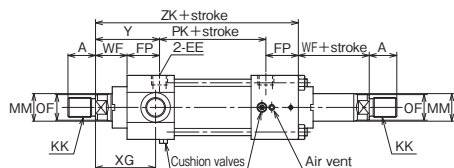

- The distance between the covers of the double rod cylinder is longer than that of the single rod cylinder by 10 mm.

### With Boots

100H-2/TQH2 [Bore] K

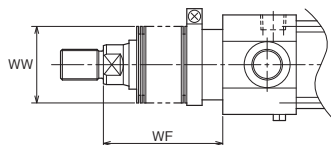

### Dimension WF

Nylon tarpaulin	$\left( \begin{array}{l} \phi 32 \cdot \phi 40 \\ \phi 50 \\ \phi 63 \text{ to } \phi 100 \\ \phi 125 \end{array} \right)$	$\left( \begin{array}{l} 1/3 \text{ stroke} + X \\ 1/3.5 \text{ stroke} + X \\ 1/4 \text{ stroke} + X \\ 1/5 \text{ stroke} + X \end{array} \right)$
Chloroprene		
Conex	$\left( \begin{array}{l} \phi 32 \\ \phi 40 \cdot \phi 50 \\ \phi 63 \text{ to } \phi 100 \\ \phi 125 \end{array} \right)$	$\left( \begin{array}{l} 1/2 \text{ stroke} + X \\ 1/2.5 \text{ stroke} + X \\ 1/3 \text{ stroke} + X \\ 1/3.5 \text{ stroke} + X \end{array} \right)$

- If the calculated WF has a fractional part, round it up.

	Standard	Semi-standard	
Material	Nylon tarpaulin	Chloroprene	Conex
Heat proof	80°C	130°C	200°C

### Notes

- Remember that the heat proof field in the table above shows the allowable temperatures for the boots, not for the cylinder.
- Conex is the registered trademark of Teijin Limited.
- The boots have been mounted at our factory prior to delivery.

### Dimensional Table

Symbol Bore	A	B		KK	MM	OF	S	SL	VD
		Standard type	Cutting oil proof type						
φ32	18	φ30f9	φ34f9	M14×1.5	φ18	φ17	14	10	10
φ40	22	φ34f9	φ40f9	M16×1.5	φ22	φ21	17	9	12
φ50	28	φ42f9	φ46f9	M20×1.5	φ28	φ26	22	11	15
φ63	36	φ50f9	φ55f9	M27×2	φ36	φ34	30	14	15
φ80	45	φ60f9	φ65f9	M33×2	φ45	φ43	38	17	8
φ100	56	φ72f9	—	M42×2	φ56	φ54	50	21	16
φ125	63	φ88f9	—	M48×2	φ70	φ68	60	24	13

Symbol Bore	AE	BB	DE	E	EE	FF	FP	JR	PJ	PK	PL	TC
φ32	12 (Note 1)	7	φ21.5	□45	Rc1/4	G1/4	35	R2	56	66	12	44h14
φ40	12	7	φ25.5	□52	Rc3/8	G3/8	33	R2	58	68	14	55h14
φ50	12	9	φ25.5	□65	Rc3/8	G3/8	33	R2	58	68	14	68h14
φ63	14	9	φ30 or more	□76	Rc1/2	G1/2	35	R2.5	66	76	16	80h14
φ80	14	11	φ30 or more	□94	Rc1/2	G1/2	42	R2.5	74	84	15	100h14
φ100	16	14	φ36.9 or more	□114	Rc3/4	G3/4	38	R3	86	96	19	120h14
φ125	16	16	φ36.9 or more	□140	Rc3/4	G3/4	39	R3	93	103	19	145h14

Symbol Bore	TD	TL	UT	WF	XG	XH	ZJ	ZK
φ32	φ16f8	12	68	25	54	74	128	161
φ40	φ16f8	12	79	25	54	76	130	159
φ50	φ20f8	16	100	32	61	76	137	166
φ63	φ25f8	20	120	34	67	84	151	180
φ80	φ32f8	25	150	35	73	93	166	203
φ100	φ40f8	32	184	41	79	105	184	213
φ125	φ50f8	40	225	41	71	121	192	222

- Note 1) • The 32 mm bore cylinder with G thread port has a thread length adjusting spacer on the rod side.  
• The tolerance of MM is f8.

### With Boots

Symbol Bore	φ32	φ40	φ50	φ63	φ80	φ100	φ125
WW	φ40	φ50	φ50	φ71	φ80	φ100	φ100
X	56	56	58	71	73	75	89

100H-2/TQH2 [Bore]B CAD/DATA is available.

### TC

100H-2 2 TC [Bore] B [Stroke] - [A] [B]

Port G thread type

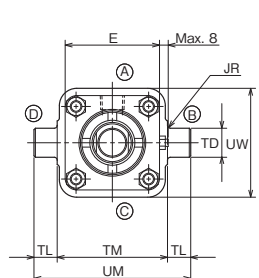
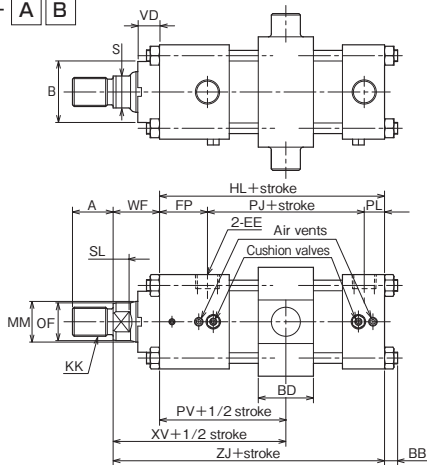
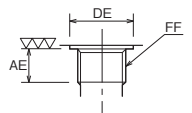

### Double acting double rod

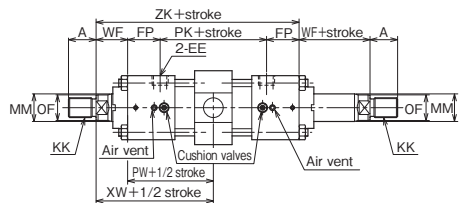

- The positions of cushion valves and air vents depend on the cylinder bore.
- Rod end thread length (dimension A) is longer when a lock nut is attached to the rod end. Refer to "Thread length of rod end with lock nut" in "Rod End Attachment."
- If the stroke is short, take care that the cushion valve does not get into contact with the mounting bracket.
- If you want to change the rod protrusion length, specify dimension WF. (Dimensions XV and XW apply in the case where WF is the standard value.)
- The TC accessory must be normally positioned in the center. When changing the position, contact us.

- The distance between the covers of the double rod cylinder is longer than that of the single rod cylinder by 10 mm.

### Minimum Stroke of TC Style

Bore	φ32	φ40	φ50	φ63	φ80	φ100	φ125
Min. stroke	10	50	50	50	100	100	100

Note) • For the min. strokes of Switch Set Cylinders, refer to the page of model numbers.

### With Boots

100H-2/TQH2 [Bore]K

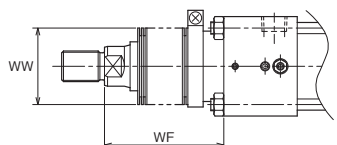

	Standard	Semi-standard	
Material	Nylon tarpaulin	Chloroprene	Conex
Heat proof	80°C	130°C	200°C

#### Notes)

- Remember that the heat proof field in the table above shows the allowable temperatures for the boots, not for the cylinder.
- Conex is the registered trademark of Teijin Limited.
- The boots have been mounted at our factory prior to delivery.

### Dimension WF

Nylon tarpaulin	φ32-φ40	1/3 stroke+X
Chloroprene	φ50	1/3.5 stroke+X
	φ63 to φ100	1/4 stroke+X
	φ125	1/5 stroke+X

Conex	φ32	1/2 stroke+X
	φ40 · φ50	1/2.5 stroke+X
	φ63 to φ100	1/3 stroke+X
	φ125	1/3.5 stroke+X

- If the calculated WF has a fractional part, round it up.

### Maximum Allowable Pressure of TC Style

When the TC accessory is at the normal position (center) and load is applied on one side

Bore	φ32	φ40	φ50	φ63	φ80	φ100	φ125
Max. allowable pressure (MPa)	10	10	10	10	7	7	7

### Dimensional Table

Symbol Bore	A	B		KK	MM	OF	S	SL	VD
		Standard type	Cutting oil proof type						
φ32	18	φ30f9	φ34f9	M14×1.5	φ18	φ17	14	10	10
φ40	22	φ34f9	φ40f9	M16×1.5	φ22	φ21	17	9	12
φ50	28	φ42f9	φ46f9	M20×1.5	φ28	φ26	22	11	15
φ63	36	φ50f9	φ55f9	M27×2	φ36	φ34	30	14	15
φ80	45	φ60f9	φ65f9	M33×2	φ45	φ43	38	17	8
φ100	56	φ72f9	-	M42×2	φ56	φ54	50	21	16
φ125	63	φ88f9	-	M48×2	φ70	φ68	60	24	13

Symbol Bore	AE	BB	BD	DE	E	EE	FF	FP	HL	JR	PJ	PK	PL
φ32	12 (Note 1)	7	30	φ21.5	□45	Rc1/4	G1/4	35	103	R2	56	66	12
φ40	12	7	30	φ25.5	□52	Rc3/8	G3/8	33	105	R2	58	68	14
φ50	12	9	38	φ25.5	□65	Rc3/8	G3/8	33	105	R2	58	68	14
φ63	14	9	43	φ30 or more	□76	Rc1/2	G1/2	35	117	R2.5	66	76	16
φ80	14	11	53	φ30 or more	□94	Rc1/2	G1/2	42	131	R2.5	74	84	15
φ100	16	14	63	φ36.9 or more	□114	Rc3/4	G3/4	38	143	R3	86	96	19
φ125	16	16	73	φ36.9 or more	□140	Rc3/4	G3/4	39	151	R3	93	103	19

Symbol Bore	PV	PW	TD	TL	TM	UM	UW	WF	XV	XW	ZJ	ZK
φ32	63	68	φ16f8	12	55h14	79	55	25	88	93	128	161
φ40	62	67	φ16f8	12	63h14	87	63	25	87	92	130	159
φ50	62	67	φ20f8	16	76h14	108	75	32	94	99	137	166
φ63	68	73	φ25f8	20	88h14	128	88	34	102	107	151	180
φ80	79	84	φ32f8	25	114h14	164	107	35	114	119	166	203
φ100	81	86	φ40f8	32	132h14	196	126	41	122	127	184	213
φ125	85.5	90.5	φ50f8	40	165h14	245	157	41	126.5	131.5	192	222

- Note 1) • The 32 mm bore cylinder with G thread port has a thread length adjusting spacer on the rod side.  
• The tolerance of MM is f8.

### With Boots

Symbol Bore	φ32	φ40	φ50	φ63	φ80	φ100	φ125
WW	φ40	φ50	φ50	φ71	φ80	φ100	φ100
X	56	56	58	71	73	75	89

### Switch Set

100H-2R 2 SD Bore B B Stroke - A B Sensor symbol Sensor quantity

#### AX/AZ type (Reed sensor/Solid state sensor)

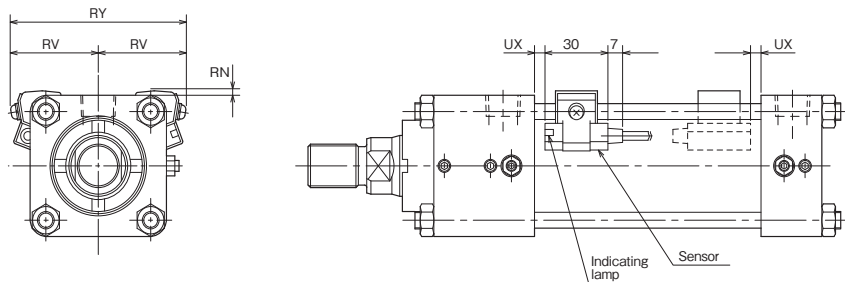

#### WR type (Reed sensor), WS type (Solid state sensor/2-wire, 2-LED type) (Cutting oil proof type)

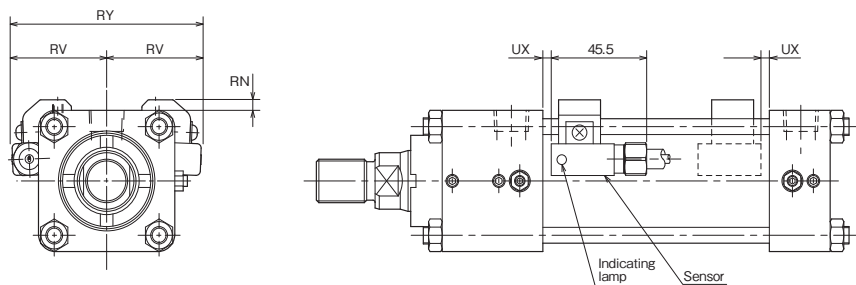

### Dimensional Table

Symbol	RN		RV		RY		UX		
	AX type	WR type	AX type	WR type	AX type	WR type	AX type	WR type	WS type
Bore	AX205W	WS type	AX205W	WS type	AX205W	WS type	AX205W	WR type	WS type
φ32	4	6	33	39	66	78	4(9)	2(7)	4(9)
φ40	4	5	37	40	74	80	5(10)	2(7)	4(9)
φ50	3	5	42	46	84	92	5(10)	2(7)	4(9)
φ63	1	4	46	51	92	102	6(11)	3(8)	5(10)
φ80	2	3	55	58	110	116	8(13)	5(10)	7(12)
φ100	3	5	65	70	130	140	11(16)	8(13)	10(15)
φ125	4	1	76	80	152	160	14(19)	11(16)	13(18)

- Notes
- The figures on the previous page show the AX type sensor (rear wiring). As for the AZ type sensor (upper wiring), take into consideration the bending radius of the cord.
  - Dimension UX indicates the appropriate sensor position for detection of stroke end.
  - The parenthesized values apply to double rod cylinders.

### Operating Range and Hysteresis

Bore (mm)	Reed sensor				Solid state sensor					
	AX1 * *		WR type		AX2 * *		AX2 * *W		WS type	
	Operating range	Hysteresis	Operating range	Hysteresis	Operating range	Hysteresis	Operating range	Hysteresis	Operating range	Hysteresis
φ32	4 to 14	2 or less	5 to 10	2 or less	3 to 8	1 or less	8 to 14	2 or less	8 to 14	2 or less
φ40	5 to 10		6 to 9		3 to 8					
φ50			6 to 9		3 to 8					
φ63	7 to 11		8 to 10		3 to 7					
φ80			8 to 10		3 to 7					
φ100	5 to 12		9 to 11			13 to 20		13 to 20		
φ125	8 to 17		10 to 17		4 to 10					

100H-2/TQH2 [Bore]K CAD/DATA is available.

### Rod End Attachment

#### ● Rod eye (T-end)

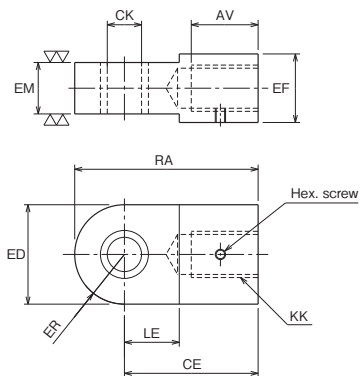

#### ● Rod clevis (Y-end)

Bore  $\phi 32$  to  $\phi 80$

Bore  $\phi 100 \cdot \phi 125$

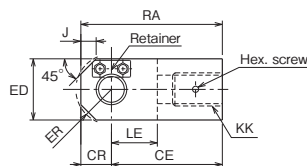
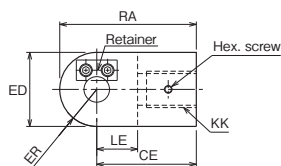
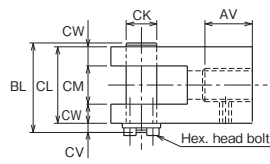
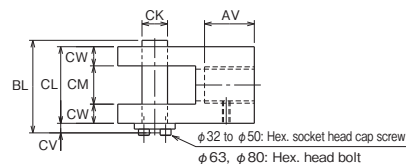

#### ● Delivery of rod end attachment (T-end or Y-end)

① When the lock nut and rod end attachment are additionally ordered  
The rod end attachment and lock nut are temporarily assembled to the piston rod for delivery. Since the lock nut is not tightened, tighten it after adjusting the position of the rod end attachment.  
No hex. screw is supplied.

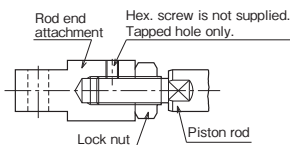

② When only the rod end attachment is additionally ordered (without lock nut)  
The rod end attachment is tightened to the piston rod, and a drill hole is made on the piston rod for delivery.  
If the drill hole is unnecessary, give us such instructions.

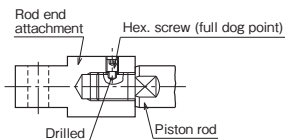

### Dimensional Table/Rod eye (T-end)

Symbol	Part number	AV	CE	EF	KK	RA	Hex. screw
$\phi 32$	RTH-14-H	21	50	25	M14×1.5	67	M6
$\phi 40$	RTH-16-3-H	25	55	30	M16×1.5	72	M6
$\phi 50$	RTH-20-4-H	31	67	35	M20×1.5	84	M6
$\phi 63$	RTH-27-H	39	78	40	M27×2	107	M6
$\phi 80$	RTH-33-1-H	48	94	50	M33×2	123	M6
$\phi 100$	RTH-42-1-H	59	112	65	M42×2	146	M8
$\phi 125$	RTH-48-4-H	66	135	75	M48×2	185	M10

Symbol	CK	ED	EM	ER	LE
$\phi 32$	$\phi 12H9$	34	16 <sup>0</sup> <sub>-0.27</sub>	R17	19
$\phi 40$	$\phi 14H9$	34	20 <sup>0</sup> <sub>-0.33</sub>	R17	19
$\phi 50$	$\phi 14H9$	34	20 <sup>0</sup> <sub>-0.33</sub>	R17	19
$\phi 63$	$\phi 20H9$	58	30 <sup>0</sup> <sub>-0.33</sub>	R29	32
$\phi 80$	$\phi 20H9$	58	30 <sup>0</sup> <sub>-0.33</sub>	R29	32
$\phi 100$	$\phi 28H9$	68	40 <sup>0</sup> <sub>-0.39</sub>	R34	39
$\phi 125$	$\phi 36H9$	100	50 <sup>0</sup> <sub>-0.39</sub>	R50	54

### Dimensional Table/Rod clevis (Y-end)

Symbol	Part number	AV	CE	KK	RA	Hex. screw
$\phi 32$	RYH-14-H	21	50	M14×1.5	67	M6
$\phi 40$	RYH-16-3-H	25	55	M16×1.5	72	M6
$\phi 50$	RYH-20-4-H	31	67	M20×1.5	84	M6
$\phi 63$	RYH-27-H	39	78	M27×2	107	M6
$\phi 80$	RYH-33-1-H	48	94	M33×2	123	M6
$\phi 100$	RYH-42-1-H	59	112	M42×2	143	M8
$\phi 125$	RYH-48-4-H	66	135	M48×2	178	M10

Symbol	BL	CK	CL	CM	CR	CV	CW	ED	ER	J	LE
$\phi 32$	42	$\phi 12H9/f8$	32	16 <sup>+0.69</sup> <sub>+0.29</sub>	—	8	8	34	R17	—	19
$\phi 40$	50	$\phi 14H9/f8$	40	20 <sup>+0.70</sup> <sub>+0.30</sub>	—	8	10	34	R17	—	19
$\phi 50$	50	$\phi 14H9/f8$	40	20 <sup>+0.70</sup> <sub>+0.30</sub>	—	8	10	34	R17	—	19
$\phi 63$	72	$\phi 20H9/f8$	60	30 <sup>+0.70</sup> <sub>+0.30</sub>	—	10	15	58	R29	—	32
$\phi 80$	72	$\phi 20H9/f8$	60	30 <sup>+0.70</sup> <sub>+0.30</sub>	—	10	15	58	R29	—	32
$\phi 100$	92	$\phi 28H9/f8$	80	40 <sup>+0.91</sup> <sub>+0.31</sub>	31	10	20	65	R33	22	39
$\phi 125$	115	$\phi 36H9/f8$	100	50 <sup>+0.92</sup> <sub>+0.32</sub>	43	13	25	90	R48	24	54



● Lock nut

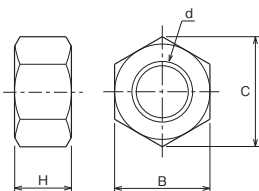

● Thread length of rod end with lock nut

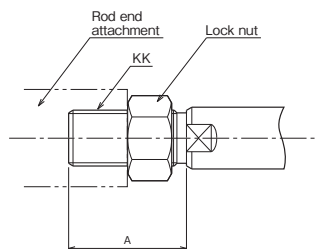

The standard fitting length of the rod end attachment and piston rod is about 80% of the thread diameter. When using a lock nut, it is necessary to increase the thread length (dimension A) as shown above.  
If you order a cylinder with a lock nut (symbol: K), the thread length (dimension A) is as shown on the next page.

Dimensional Table/Lock nut

Bore	Symbol	Rod B			
		Part number	B	C	d
φ 32	LNH-14F-H	22	25.4	M14×1.5	11
φ 40	LNH-16F-1-H	24	27.7	M16×1.5	13
φ 50	LNH-20F-2-H	30	34.6	M20×1.5	16
φ 63	LNH-27F-H	41	47.3	M27×2	22
φ 80	LNH-33F-H	50	57.7	M33×2	26
φ 100	LNH-42F-1-H	65	75.0	M42×2	34
φ 125	LNH-48F-2-H	75	86.5	M48×2	38

Dimensional Table/Dimension A when lock nut is used (long thread)

Bore	Symbol	Rod B	
		A	KK
φ 32		28	M14×1.5
φ 40		32	M16×1.5
φ 50		40	M20×1.5
φ 63		54	M27×2
φ 80		66	M33×2
φ 100		84	M42×2
φ 125		96	M48×2

## ● Parallel Pin

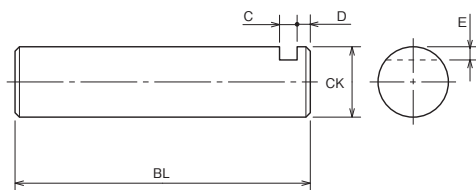

## ● Retainer

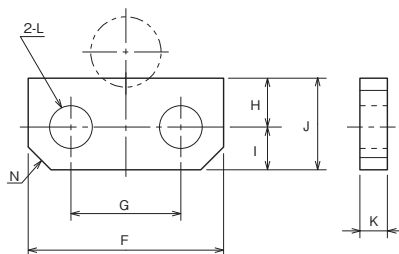

## Dimensional Table/Parallel pin

Symbol Bore	Rod B				
	BL	C	CK	D	E
φ 32	42	4	φ12f8	4	2
φ 40	50	4	φ14f8	4	2
φ 50	50	4	φ14f8	4	2
φ 63	72	5.5	φ20f8	4.5	3
φ 80	72	5.5	φ20f8	4.5	3
φ 100	92	5.5	φ28f8	4.5	4
φ 125	115	7	φ36f8	6	5

## Dimensional Table/Retainer

Symbol Bore	Rod B								Mounting bolt
	F	G	H	I	J	K	L	N	
φ 32	19	10	5.5	4.5	10	3	φ 5.5	C2.5	M5
φ 40	19	10	5.5	4.5	10	3	φ 5.5	C2.5	M5
φ 50	19	10	5.5	4.5	10	3	φ 5.5	C2.5	M5
φ 63	32	17	8	8	16	4.5	φ 6.6	C4	M6
φ 80	32	17	8	8	16	4.5	φ 6.6	C4	M6
φ 100	38	23	7	8	15	4.5	φ 6.6	C4	M6
φ 125	44	24	11	11	22	6	φ 9	C3	M8

### Change of Rod End Shape **Rod B** (For other shapes, consult us.)

■ You can specify the shape and dimension of the rod end as shown below using the semi-standard symbols and dimension symbols.  
 (No need to specify the dimension symbol if you order a cylinder with the basic dimension. Specify only the semi-standard symbol.)

How to order **Series** **Model number** - × **Semi-standard symbol** **Dimension symbol (Specify only when the dimension differs from the basic dimension.)**

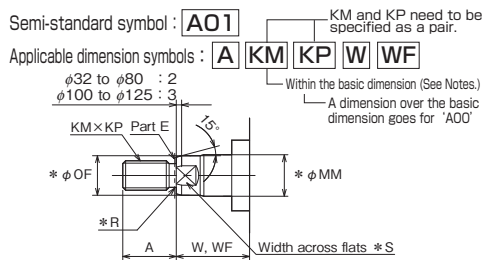

Table of Basic Dimensions (=Standard dimensions of 100H-2)

Bore	A	KM	KP	*MM	*OF	*R	*S	W (FA)	WF (Others)
φ32	18	14	1.5	φ18	φ17	1	14	35	25
φ40	22	16	1.5	φ22	φ21	1.6	17	35	25
φ50	28	20	1.5	φ28	φ26	1.6	22	41	32
φ63	36	27	2	φ36	φ34	2	30	48	34
φ80	45	33	2	φ45	φ43	2	38	51	35
φ100	56	42	2	φ56	φ54	2	50	57	41
φ125	63	48	2	φ70	φ68	2	60	57	41

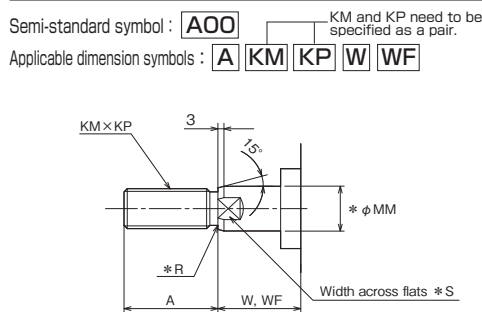

Table of Basic Dimensions (Standard dimensions)

Bore	A	KM	KP	*MM	*R	*S	W (FA)	WF (Others)
φ32	25	16	1.5	φ18	1	14	35	25
φ40	30	20	1.5	φ22	1	19	35	25
φ50	35	24	1.5	φ28	1	24	41	32
φ63	45	30	1.5	φ36	1.6	30	48	34
φ80	60	39	1.5	φ45	1.6	41	51	35
φ100	75	48	1.5	φ56	1.6	50	57	41
φ125	95	64	2	φ70	2	65	57	41

● The \*-marked dimensions are fixed.  
 ● If it is necessary to change the fixed dimensions, consult us.

**Usage**

■ To change the dimensions of the rod end shape of 100H-2

**Notes**

■ When the dimensions are identical to the basic dimensions, the semi-standard symbol is unnecessary because the basic dimensions are the same as the standard dimensions.  
 ■ When a thread size that differs from the basic dimension is specified, the part E will not have a contact area. Therefore, the rod end will have the shape of 'A00'. In this case, the semi-standard symbol must be 'A00'. ('A01' cannot be used.)

Use symbol **A00** and specify the dimensions.

**Examples**

● Bore: 40 mm, rod B, rod end thread: M16×2, WF=80 mm  
 (Order) 100H-2 1CA40BB250-AB-X A01  
 KM-16, KP-2, WF-80  
 (Fabrication) Rod end shape A=22, KM=16, KP=2, WF=80, φMM=φ22, φOF=φ21, R=1.6, S=17

● Bore: 100 mm, rod B, rod end thread: M45×1.5 'A01' cannot be used.

**Usage**

■ To specify a thread size different from the basic dimension of 'A01'  
 ■ To conform to the rod end thread pitch of the rod B of TAIYO 70H-8

**Notes**

■ The basic dimensions A, KM and KP of 'A00' differ from those of 'A01'.  
 ■ When using symbol 'A00' to specify a thread size different from the basic dimension of 'A01', specify dimension A at the same time.

**Examples**

● Bore: 63 mm, rod B, with basic dimensions of 'A00' (Order) 100H-2R 2FA63BB300-BC-X A00 (Fabrication) Rod end shape A=45, KM=30, KP=1.5, W=48, φMM=φ36, R=1.6, S=30

● Bore: 100 mm, rod B, rod end thread: M45×1.5, with other standard dimensions of 100H-2 (=basic dimensions of 'A01')  
 Since the thread differs from the basic dimension of 'A01', the shape must be 'A00'.  
 (Order) 100H-2 2CB100BR500-AB-X A00  
 KM-45, KP-1.5, A-56  
 (Fabrication) Rod end shape A=56, KM=45, KP=1.5, WF=41, φMM=φ56, R=1.6, S=50

● Bore: 50 mm, rod B, shape: A00, rod end thread: M22×1.5, WF=100 mm, with other basic dimensions of 'A01'  
 (Order) 100H-2 2CA50BB500-AB-X A00  
 KM-22, KP-1.5, WF-100  
 (Fabrication) Rod end shape A=35, KM=22, KP=1.5, WF=100, φMM=φ28, R=1, S=24

### **Rod B** Special Rod End Shapes

#### A51

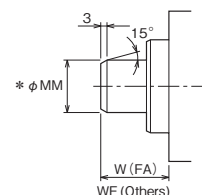

#### A81

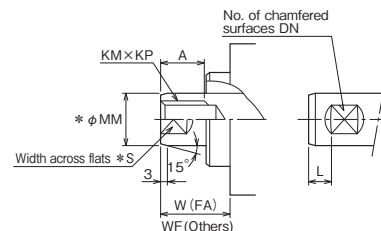

Table of Basic Dimensions

Bore	A	DN	KM	KP	L	*MM	*S	W (FA)	WF (Others)
φ32	15	2	M12	1.75	0	φ18	14	35	25
φ40	20	2	M16	2	0	φ22	19	35	25
φ50	24	2	M20	2.5	0	φ28	24	41	32
φ63	33	2	M27	3	0	φ36	30	48	34
φ80	36	2	M30	3.5	0	φ45	41	51	35
φ100	45	2	M39	4	0	φ56	50	57	41
φ125	58	2	M48	2	0	φ70	65	57	41

#### A82

Fitting (separate flange joint) is available.

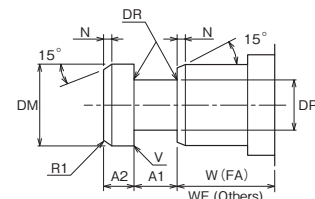

Table of Basic Dimensions

Bore	*A1 <sup>-0.5/+0.3</sup>	*A2 <sup>-0.2/+0.3</sup>	*DM	*DP <sup>-0.2/+0.3</sup>	*DR	*MM	*N	*V	W (FA)	WF (Others)
φ32	12.5	12.5	φ18	φ13	1.0	φ18	3	C0.2	35	25
φ40	12.5	12.5	φ22	φ16	1.5	φ22	3	C0.2	35	25
φ50	12.5	12.5	φ28	φ21	1.5	φ28	3	C0.2	41	32
φ63	15	15	φ36	φ26	2.0	φ36	3	C0.2	48	34
φ80	15	15	φ45	φ31	2.0	φ45	3	C0.2	51	35
φ100	20	20	φ56	φ38	3.0	φ56	3	C0.2	57	41
φ125	25	25	φ70	φ49	3.5	φ70	3	R1	57	41

MM is the rod diameter.

● The \*-marked dimensions are fixed.  
 ● If it is necessary to change the fixed dimensions, consult us.